

SAFETY PRODUCTS

Eden DYN

Coded non-contact safety sensor

Product Manual



Read and understand this document

Please read and understand this document before using the products. Please consult ABB with any questions or comments.

Suitability for use

ABB shall not be responsible for conformity with any standards, codes, or regulations that apply to the combination of products in the customer's application or use of the product. Third party certificates for the products are available at <https://new.abb.com/low-voltage/products/safety-products>. This information by itself is not sufficient for a complete determination of the suitability of the products in combination with the end product, machine, system, or other application or use.

The following are some examples of applications for which particular attention must be given. This is not intended to be an exhaustive list of all possible uses of the products, nor is it intended to imply that the uses listed may be suitable for the products:

- Outdoor use, uses involving potential chemical contamination or electrical interference, or conditions or uses not described in this document.
- Nuclear energy control systems, combustion systems, railroad systems, aviation systems, medical equipment, amusement machines, vehicles, and installations subject to separate industry or government regulations.
- Systems, machines, and equipment that could present a risk to life or property.

Please know and observe all prohibitions of use applicable to the products.

NEVER USE THE PRODUCTS FOR AN APPLICATION INVOLVING SERIOUS RISK TO LIFE OR PROPERTY WITHOUT ENSURING THAT THE SYSTEM AS A WHOLE HAS BEEN DESIGNED TO ADDRESS THE RISKS, AND THAT THE ABB PRODUCT IS PROPERLY RATED AND INSTALLED FOR THE INTENDED USE WITHIN THE OVERALL EQUIPMENT OR SYSTEM.

Descriptions and examples show how the product works and can be used. It does not mean that it fulfills the requirements for all types of machines and processes. The buyer/user is responsible for installing and using the product according to applicable standards and regulations. We reserve the right to make changes to the product and the documentation without prior notice.

Table of Contents

1	Introduction.....	5
	Scope.....	5
	Audience.....	5
	Prerequisites.....	5
	Special notes.....	5
2	Safety.....	6
	Safety precautions.....	6
3	Product description.....	7
	Models of Adam and Eva.....	8
	Adam DYN.....	8
	Eva.....	9
4	Electrical connections.....	10
	Adam DYN-Info M12-5.....	10
	Adam DYN-Reset M12-5.....	11
	Adam DYN-Status M12-5.....	11
	Connection of cable C5 to M12 C01 and M12 C02 connectors.....	12
	Parallel connection with Eden.....	12
	Information output signal attributes.....	12
	Connection of Reset button to Adam DYN-Reset.....	13
	Serial connection.....	14
5	Connection examples.....	15
	Adam DYN-Info connected to Vital 1.....	15
	Several Adam DYN-Info connected in series to Vital 1.....	16
	Several Adam DYN-Status connected in series to Pluto.....	16
	Several Adam DYN-Status connected in series to Pluto via M12-3S.....	17
	Y-connectors.....	17
6	Installation.....	18
	Installation precautions.....	18
	Minimum safety distance.....	18
	Detection distance.....	19
	Mounting.....	20
	Mounting procedure.....	21
	Teaching the code.....	22

How to program a new Adam without code, to accept a new Eva	22
How to erase existing codes from Adam	22
Replacing Eva (Not needed for General to General switch).....	22
Testing the safety functions	23
Info output (pin-5) – Information/StatusBus	24
Setting StatusBus address.....	24
7 LED indication	25
8 Maintenance	26
Maintenance precautions	26
Troubleshooting.....	26
9 Compatibility with analog models of Eden.....	27
10 Model overview	28
Accessories	28
11 Technical data	29
Guideline for chemical resistance.....	31
Eden dimensions	32
CAD model	32
12 Declaration of conformity	33

1 Introduction

Scope

The purpose of these instructions is to describe the non-contact coded digital safety sensor Eden DYN and to provide the necessary information required for installation and operation.

Audience

This document is intended for authorized installation personnel.



Prerequisites

It is assumed that the reader of this document has knowledge of the following:

- Basic knowledge of ABB safety products.
- Knowledge of machine safety.

Special notes

Pay attention to special notes in the document:





-  **Warning!** Risk of severe personal injury!
An instruction or procedure which, if not carried out correctly, may result in injury to the technician or other personnel.
-  **Caution!** Risk of damage to the equipment!
An instruction or procedure which, if not carried out correctly, may damage the equipment.
-  **Note!** Important or explanatory information.

2 Safety

Safety precautions

The safety precautions must be followed during installation, operation, maintenance and troubleshooting.

It is the responsibility of the user to ensure the correct overall functionality of its systems and machines.

-  **Warning!** Carefully read through the entire product manual before using the device.
-  **Warning!** The devices shall be installed by authorized personnel following the Safety regulations, standards and the Machinery directive.
-  **Warning!** Failure to comply with instructions, operation that is not in accordance with the use prescribed in the instructions, improper installation or handling of the device can affect the safety of people and the plant.
-  **Warning!** For installation and prescribed use of the product, the special notes in the instructions must be carefully observed and the technical standards relevant to the application must be considered.
-  **Warning!** In case of failure to comply with the instructions or standards, especially when tampering with and/or modifying the product, any liability is excluded.

3 Product description

Eden DYN sensor consists of two separate devices, Adam and Eva, intended for use as interlocking device for gates, hatches etc. Eva can be general coded or unique coded.

Eden DYN meets the coding requirements according to EN ISO 14119:2013 regarding manipulation protection.

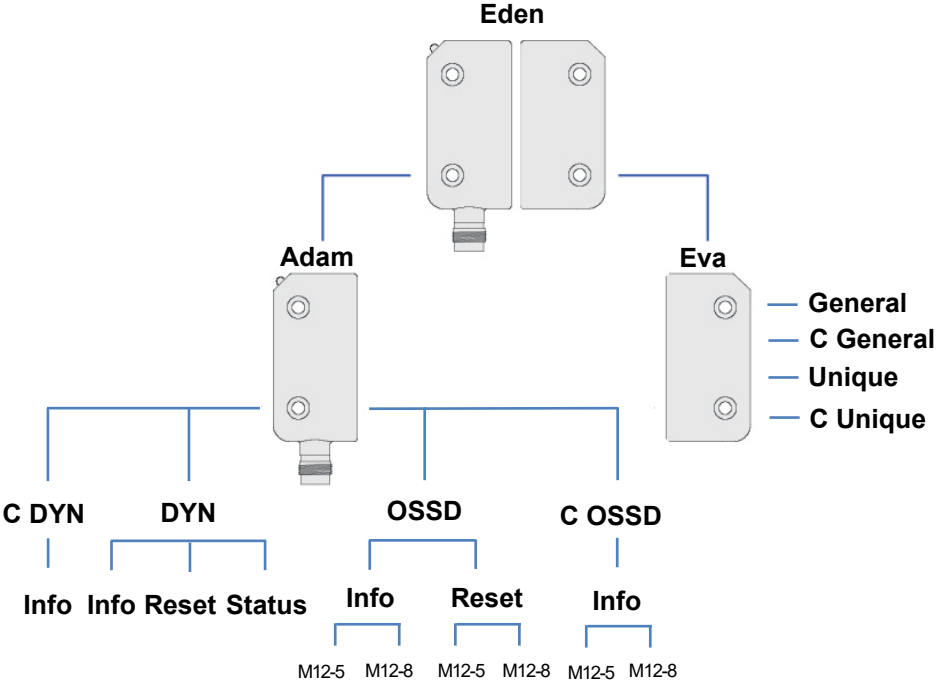

Eden digital, relationship

Models of Adam and Eva

Eden communicates with a dynamic signal (DYNlink) generated by the control device, a Vital, a Pluto Safety PLC or a URAX. Up to 30 Eden sensors can be connected in series to Vital 1. Ten Eden sensors can be connected to one Pluto or URAX input, without reducing the achieved performance level.

It is also possible to connect Tina adaptor units and E-stops in the same safety circuit. Adam and Eva are acquired separately, and it is possible to mix different models of Adam DYN in the same safety circuit.

Adam DYN

Adam DYN exists in different models: Adam DYN-Info, Adam C DYN-Info, Adam DYN-Reset and Adam DYN-Status.



Adam DYN-Info M12-5

DYNlink model with information output.

Adam C DYN-Info M12-5

DYNlink model with information output and coated electronics to provide increased resistance in demanding environments.

Adam DYN-Reset M12-5

DYNlink model with built in monitored reset and indication lamp output.

Adam DYN-Status M12-5

DYNlink model with StatusBus function. Adam DYN-Status is delivered configured for static information output, but switches to StatusBus configuration when a StatusBus master has been detected. Requires a Pluto as master. (For more information about the Pluto, refer to the user manual at new.abb.com/low-voltage/products/safety-products)

Eva

Eva exists in different models: Eva General code, Eva C General code, Eva Unique code and Eva C Unique code. It is possible to mix different models of Eva in the same safety circuit.



Eva General code

The Eva units with general code have all the same code and fulfills the requirement for a low-level coded interlocking device according to EN ISO 14119:2013.

Eva C General code

Eva general code with coated electronics to provide increased resistance in demanding environments.

Eva Unique code

The Eva units with unique code have all a different unique code. The unique models fulfill the requirements for a high-level coded interlocking device according to EN ISO 14119:2013.

Eva C Unique code

Eva unique code with coated electronics to provide increased resistance in demanding environments.

4 Electrical connections

Note! Use a suitably insulated low-voltage supply system type SELV or PELV.

Adam DYN-Info M12-5

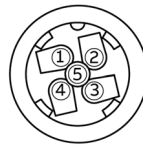
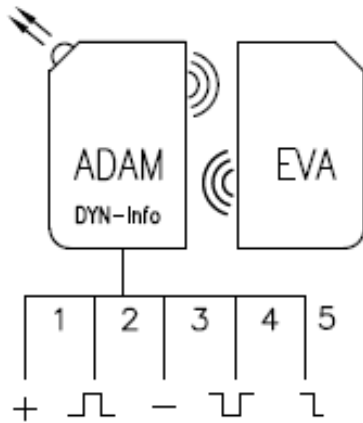

M12 5-pole male
from cable side



M12 5-pole female
from cable side

M12-connector: (5-pole male)

- 1) Brown: +24 VDC
- 2) White: DYNlink signal in
- 3) Blue: 0 VDC
- 4) Black: DYNlink signal out
- 5) Grey: Info

Adam DYN-Reset M12-5

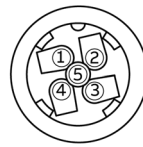
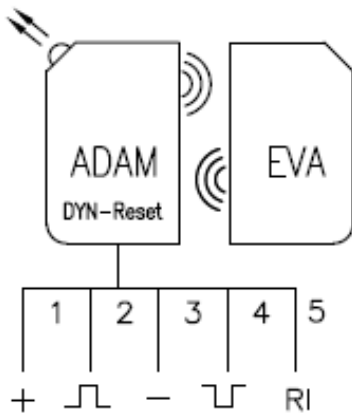

M12 5-pole male
from cable side

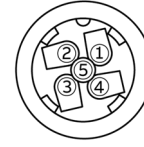

M12 5-pole female
from cable side

M12-connector: (5-pole male)

- 1) Brown: +24 VDC
- 2) White: DYNlink signal in
- 3) Blue: 0 VDC
- 4) Black: DYNlink signal out
- 5) Grey: Reset/Indication

Adam DYN-Status M12-5

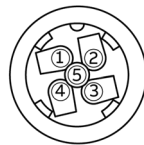
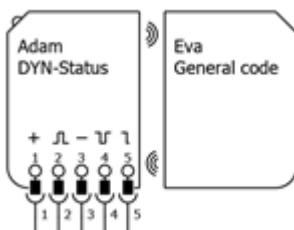

M12 5-pole male
from cable side

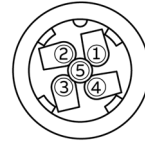

M12 5-pole female
from cable side

M12-connector: (5-pole male)

- 1) Brown: +24 VDC
- 2) White: DYNlink signal in
- 3) Blue: 0 VDC
- 4) Black: DYNlink signal out
- 5) Grey: Info/StatusBus

Note! The use of shielded cable is recommended for enhanced electromagnetic immunity.

Caution! All cable colors according to ABB standard cables.

Connection of cable C5 to M12 C01 and M12 C02 connectors

Female 5-pin connector (M12 C01):

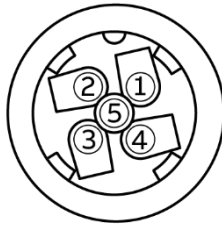

- 1) Brown
- 2) White
- 3) Blue
- 4) Black
- 5) Grey

Male 5-pin connector (M12 C02):

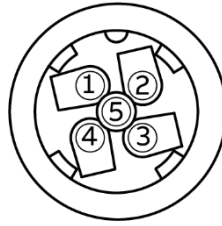
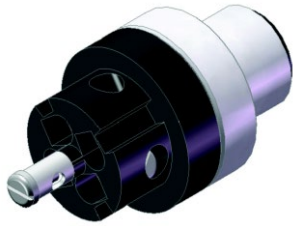

Parallel connection with Eden

Eden can be connected in parallel with other DYNlink devices in a safety circuit, to create a muting/bypass function. M12-3B can be used for an easy connection.

Switching a DYNlink device on or off while connected in parallel could cause a short interruption of the safety circuit even if one of the branches are on during the switch.

Information output signal attributes

Adam DYN-Info and Adam DYN-Status in non-StatusBus mode are equipped with an information output on pin-5. When Eva is in contact with Adam, the pin-5 is set high (+24 VDC).

The maximum current consumption for the information output is 15 mA.

⚠ Warning! The information output signal is not a failsafe signal and must **never** be used for the safety purpose(s).

Connection of Reset button to Adam DYN-Reset

Adam DYN-Reset is a model prepared for monitored local reset. A reset light button can be connected to pin 5 and Adam DYN-Reset handles the monitored reset and the indication lamp of the reset button. Each Eden with a local reset is reset individually. Only when all Eden units in the safety circuit have been reset, the safety circuit itself is reset and the machine can be restarted.

Any button with a NO-contact and an indication lamp can be used. See electrical connection below. The maximum current consumption for the indication lamp is 30 mA. Smile 12RF is a reset button with indication lamp from ABB intended to be used together with Adam DYN-Reset. The minimum current consumption needed through the lamp is 10 mA. If no lamp is used, a 4.7 kOhm resistor can be used instead.

The reset signal is accepted as valid only when the reset signal is high for more than 100 ms but less than 3 seconds.

Cable length between Reset button and Adam sensor: max 10 m.

Reset indication lamp status	Description
On:	No valid Eva is detected, safety circuit is open.
Flash (0.4 s on / 0.6 s off):	Valid Eva is detected. Waiting for reset.
Off:	The reset button has been pressed and the safety circuit is closed.

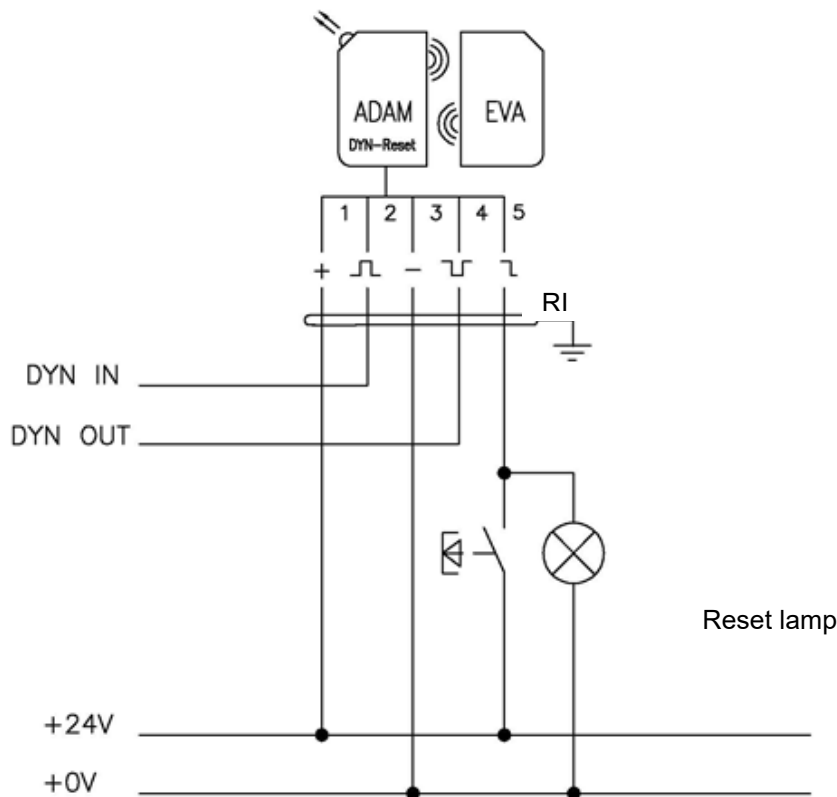

Warning! Several Eden must not be connected in parallel to a common reset button. Each Eden must be separately connected to a local reset.

Serial connection



Serial connection of three Adam DYN-Reset with Smile 12 RF to Pluto or Vital via M12-3A.

5 Connection examples

Adam DYN-Info connected to Vital 1

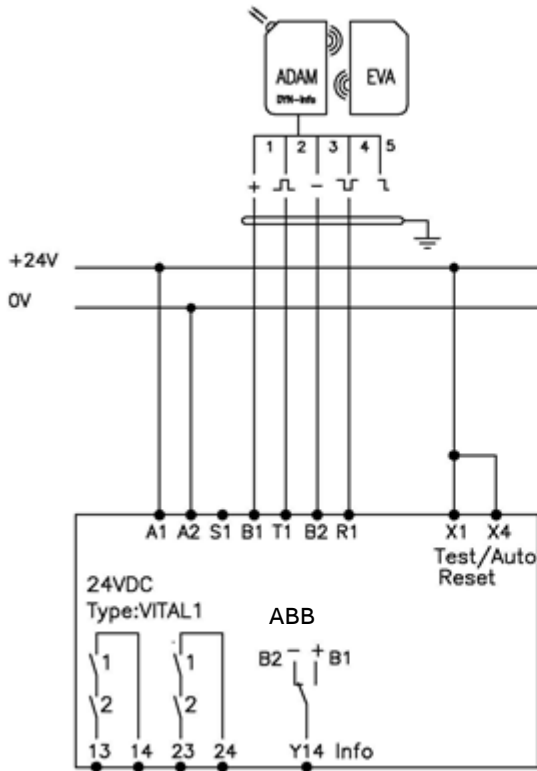

A) Adam DYN-Info connected to Vital 1 with automatic reset.

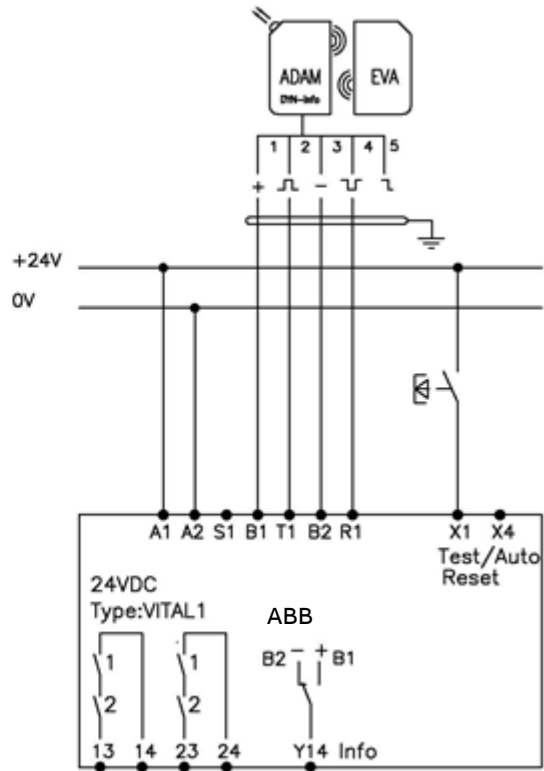

B) Adam DYN-Info connected to Vital 1 with manual reset.

Several Adam DYN-Info connected in series to Vital 1

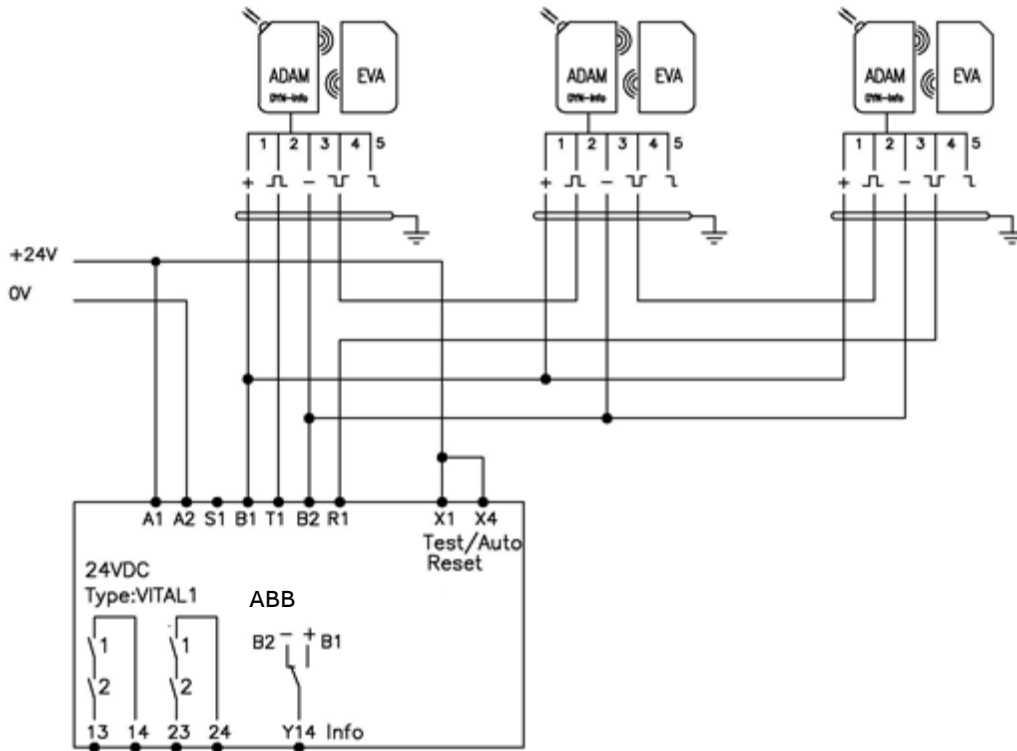

A) Three Adam DYN-Info connected to Vital 1 with automatic reset.

Several Adam DYN-Status connected in series to Pluto

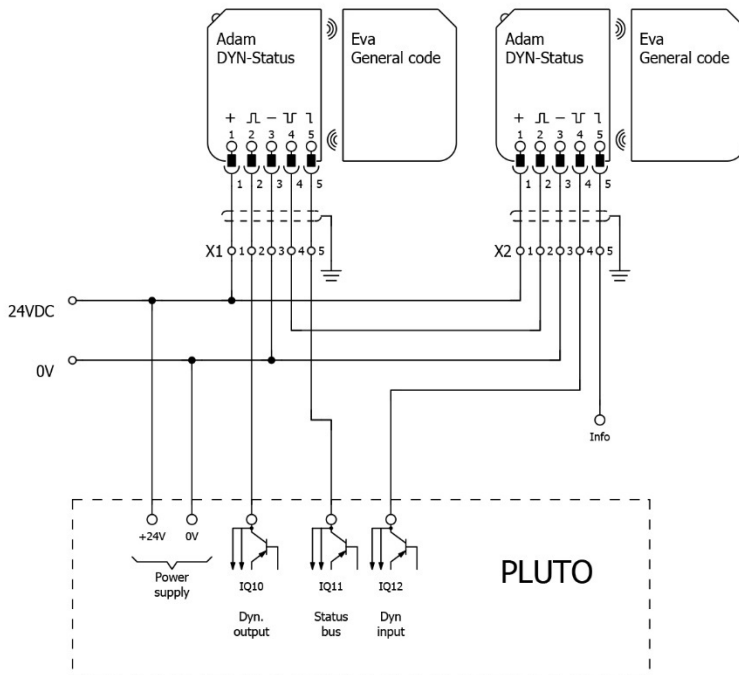

A) Two Adam DYN-Status connected to a Pluto Safety PLC. Left unit connected to use StatusBus, right unit connected to use Info.

Several Adam DYN-Status connected in series to Pluto via M12-3S

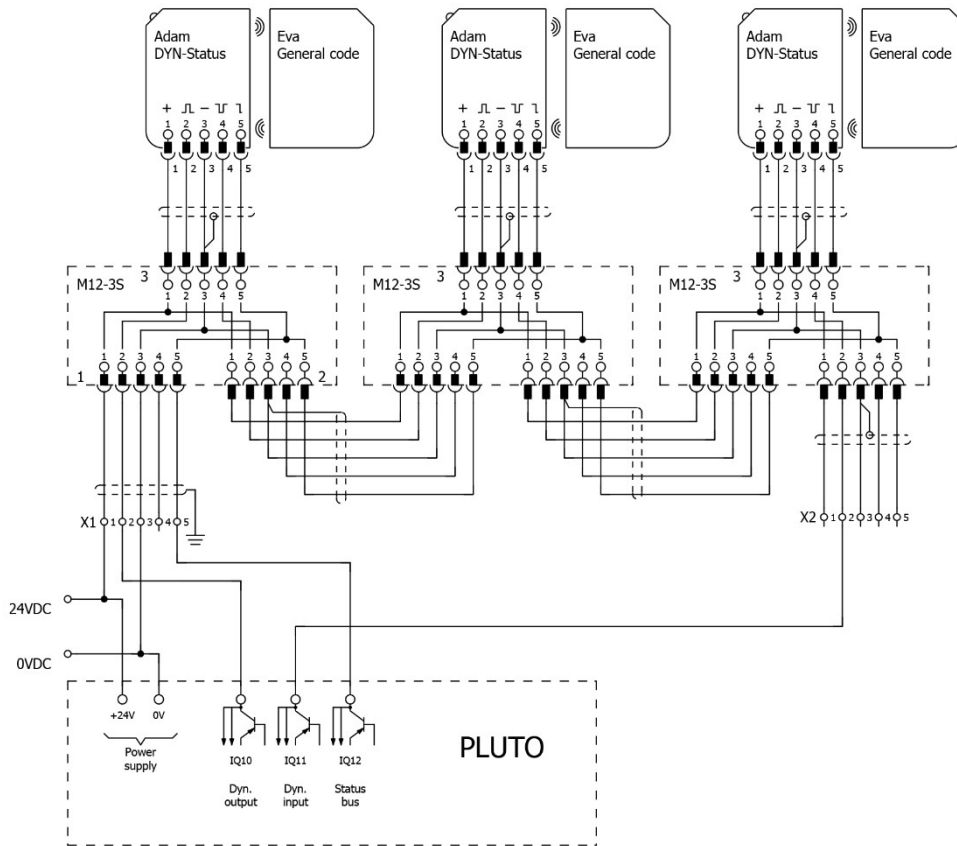

A) Three Adam DYN-Status connected to a Pluto Safety PLC via M12-3S to use StatusBus.

Y-connectors

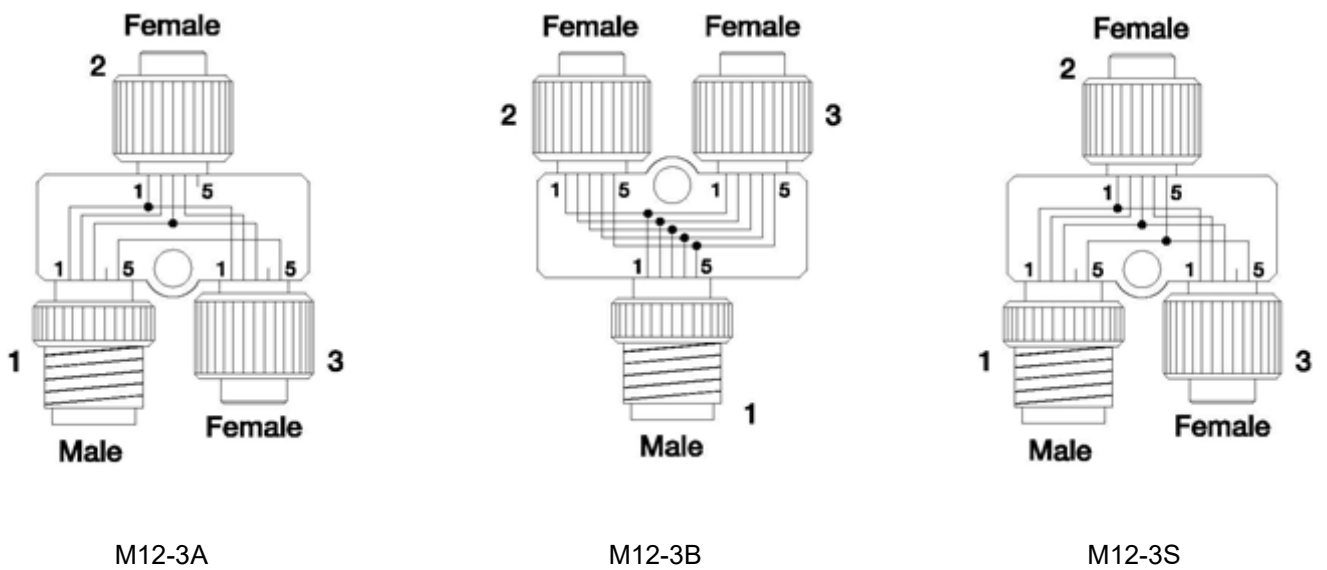

6 Installation

Installation precautions

 **Warning!** All safety functions shall be tested before starting up the system.

- Note that the detection distance can be affected when Eden is mounted close to metal.
- The Eden can be mounted on metal but must not be surrounded.
- The S_{ar} distance must be used in calculations (e.g. for minimum safety distance).
- Control that Adam and Eva are aligned in parallel to each other.

Minimum safety distance

When using interlocking guards without guard locking to safeguard a hazard zone, the minimum allowed safety distance between the guarded opening and the hazardous machine must be calculated. To ensure that the hazardous machine motion will be stopped before it can be reached, the minimum safety distance is calculated according to EN ISO 13855: 2010 (“Positioning of safeguards with respect to the approach speeds of parts of the human body”).

The minimum safety distance is calculated according to the formula:

$$S = (K \times T) + C$$

Where

S = minimum safety distance (mm)

K = approach speed of a human body; 1600 mm/s

T = the total time from opening of the guard until the hazardous machine movement has stopped, i.e. including control system reaction times and other delays (s)

C = a safety distance taken from Table 4 or Table 5 of EN ISO 13857:2008, if it is possible to push fingers or a hand through the opening towards the hazard before a stop signal is generated.

 **Note!** In some cases, **T** might be reduced by the opening time of the guard until the opening size permits access of the relevant parts of the body. Refer to EN ISO 13855:2010 for further details and EN ISO 13857:2008 for specified values.

Detection distance

Eva can be turned in several different ways relative to Adam, see details in the figure below. The green fields in the picture show the detection range of Adam relative to Eva. The Eva is detected when the two coils (see red-marked areas, image below) in Eva are in contact with the green field.

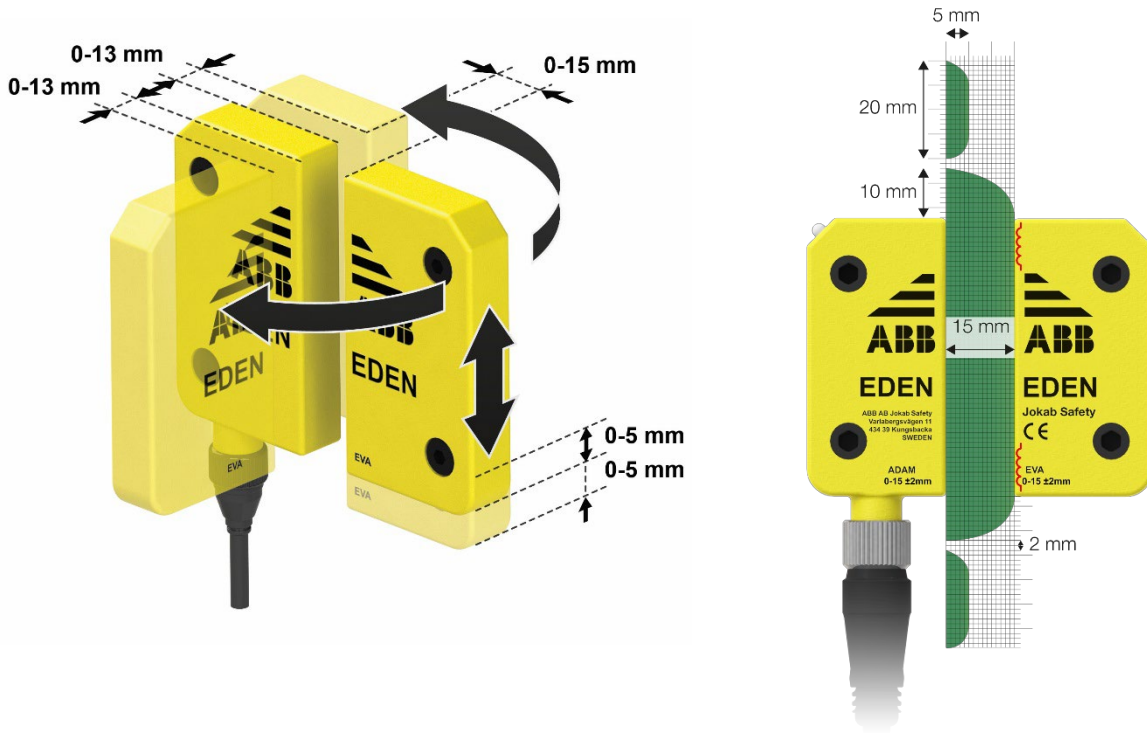

The figures above shows maximum detection distances.

Detection distance between Adam and Eva: 0-15 mm +/- 2 mm

Recommended distance between Adam and Eva: 7 mm

Minimum distance between two Eden pairs: 100 mm

! Caution! The detection distance can be affected if Eden is mounted close to metal. Distance plate DA 1B must be used to prevent this.



Distance plate (DA 1B)

Mounting

Depending on the cable connector used for the connection to Eden, one or two distance plates DA 1B might be required for correct mounting to avoid damaging Adam. It is recommended to use the distance plates DA 1B, supplied with the Adam, see figure below. Also, the mounting spacers DA 2B supplied must be used to physically protect Eden from damage.

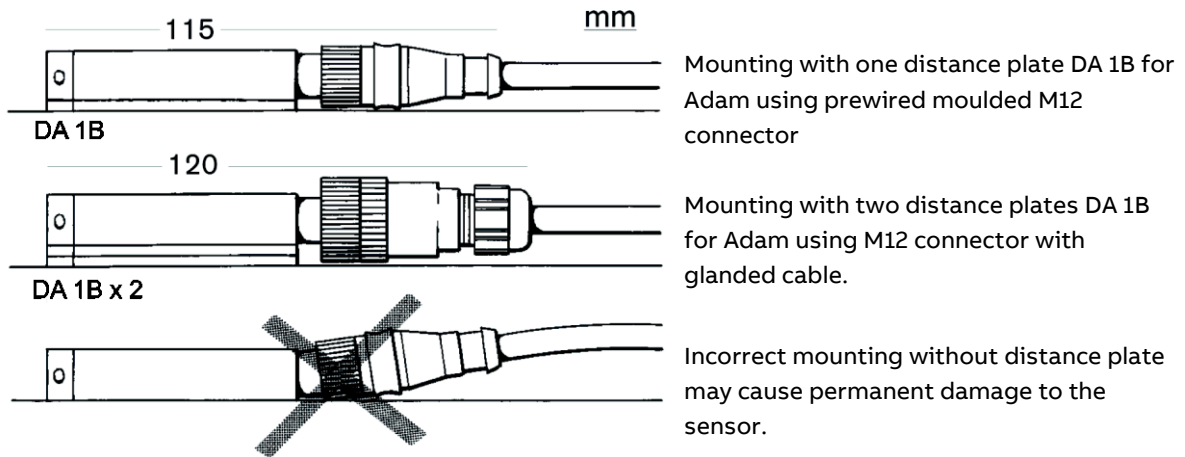

The cable must be mounted so that no force is applied on Adam in any directions. The cable must be fixed if it is connected to a moving object, for example a cable chain or a door. This can be done, with for example, two cable clamps.

! Caution! An improperly installed cable can damage the sensor.

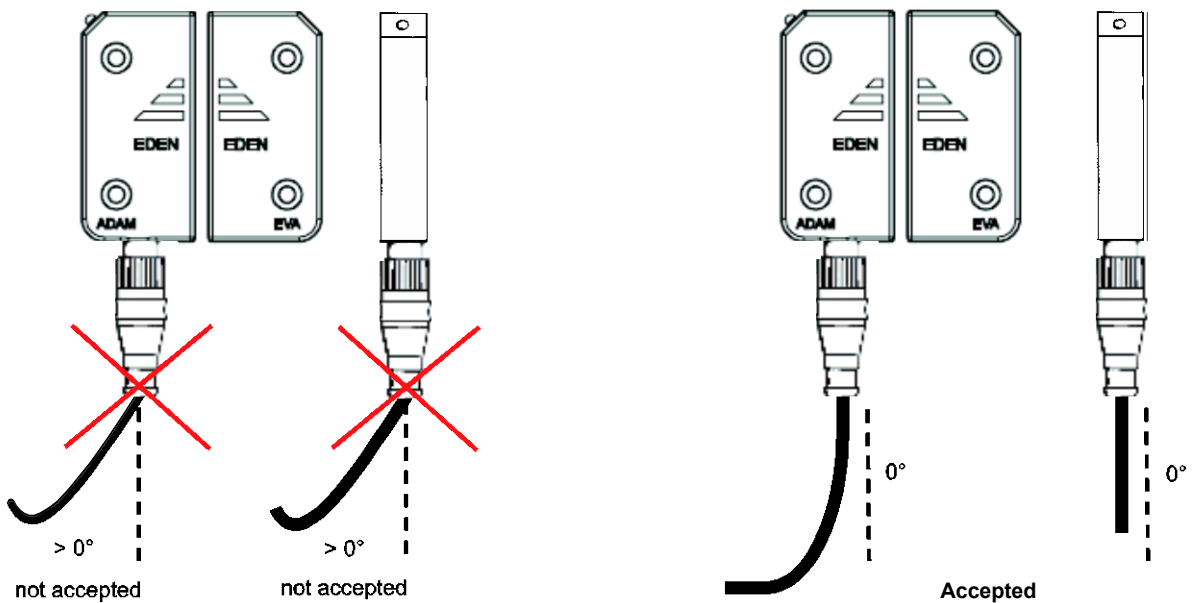

Mounting procedure

1. Fasten each sensor with two M4-screws. Safety screw SM4x20 (2TLA020053R4200) is recommended. The DA 2B mounting spacers must be used to physically protect Eden from damage.
2. Use max tightening torque 1.0 Nm on screws.
3. Lock screw with Loctite or similar if necessary, to prevent easy dismounting (refer to risk assessment).
4. Tighten the M12-connector with tightening torque 0.6 Nm. A torque wrench is recommended to ensure a tight connection and IP69K.

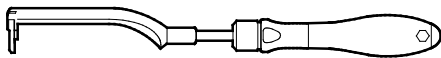
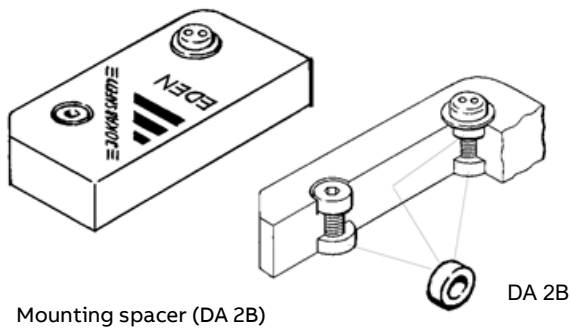

Torque wrench for M12-connector

Teaching the code

Adam is without code in its factory setting mode and need to be programmed with the code from an Eva (General or Unique coded). The code of the first Eva detected by the Adam is automatically programmed as soon as Eva is within the detection distance. If Adam is programmed to accept an Eva with a general code, it will accept all Eva units with a general code. If it is programmed to accept an Eva with unique code, it will only accept the unique code of that specific Eva.

Note that it is possible to teach more than one Adam unit to accept the same Eva unit. This is for example applicable on a sliding door or for machine positioning.

How to program a new Adam without code, to accept a new Eva

1. Bring the Eva in the range of Adam.
2. Connect the Adam without code to the power supply.
3. The LED on Adam will turn green when the programming procedure is finished.

Note! The programming procedure is taking place only at startup of Adam. Eva must be in range at this time.

Note! If the teaching procedure fails, and no Eva code is programmed, Adam enters a fail-safe mode and its red LED starts flashing fast. Erase the code, cycle the power and restart the teaching code procedure.

Note! In case of Adam DYN-Status, StatusBus operation is not possible when in fail-safe mode.

Note! The Eva must not be removed during the teaching procedure.

How to erase existing codes from Adam

1. Remove Eva from Adam's detection range.
2. Disconnect the power supply on pin 1 on the Adam unit.
3. Connect +24 VDC to pin 2.
4. Connect the power supply on pin 1 on the Adam unit.
5. After 5-10 seconds the unit LED turn green.
6. Disconnect pin 2 from +24 VDC. (Leave pin 1 connected.)
7. The Adam unit will now be reset, and its LED will flash red.
8. Follow normal installation procedure to install Adam again.

Note! If the pin 2 on the Adam unit is not disconnected from +24 VDC within 5-10 seconds, Adam enters the fail-safe mode and the red LED starts flashing fast. It is then necessary to restart the procedure from the beginning.

Replacing Eva (Not needed for General to General switch)

When an Eva Unique should be replaced, the used one needs to be deleted from the Adam sensor. To delete Eva from the internal memory, follow the instructions in "How to erase existing codes from Adam DYN".

When Adam is reset and the LED flashes red: disconnect the power supply, move the new Eva within detection distance and reconnect the power supply again. The green LED is now on and the teaching of the new Eva's code into Adam is done.

Testing the safety functions

Make sure the safety unit and safety module (Vital/Pluto/URAX) is working properly by following these steps:

1. Interrupt Eden output by moving Eva away from Adam. The LED will light red when Eva is out of range of Adam.
2. Remove interrupt by moving Eva back to within the detection distance from Adam.
3. Interrupt the DYNlink safety circuit before the unit to be tested. The LED will flash between green and red.
4. Restore the DYNlink safety circuit. The LED will light green if the safety circuit(s) before this unit is not interrupted.
5. An additional function test can be made by slowly moving Eva away from Adam. The LED will flash fast green when Eva is 2 mm from the max detection distance to Adam.

Info output (pin-5) – Information/StatusBus

The pin-5 of Adam DYN-Status has two functions:

- In its factory setting mode, Adam DYN-Status has its pin-5, configured as a static info output. This means it is high (+24 VDC) when valid Eva is within reading range (circuit OK) and low when Eva is not.
- The pin-5 of Adam DYN-Status can also be connected to the StatusBus. When so, the unit will detect StatusBus master signals and switch pin-5 mode from info output to StatusBus. Pluto is able to serve as the master in a StatusBus system and can receive status information (on/off) from Adam DYN-Status and other types of sensors with StatusBus support. Up to 30 sensors can be connected to the same StatusBus.

 **Warning!** The StatusBus signal is not a failsafe signal and must **never** be used for the safety purpose(s).

Setting StatusBus address

In its factory setting mode, Adam DYN-Status has StatusBus address set to 0. This will make it act as DYN-Info device at pin-5 until StatusBus signal is detected. When StatusBus is detected by Adam, it can receive address change command from StatusBus master (i.e. Pluto or FIXA) to obtain a valid operational address 1–30. This can be done manually or automatically done using 'Pluto Manager StatusBus Teach addresses' functionality.

For more information about the StatusBus, refer to the user manual for Pluto at: new.abb.com/low-voltage/products/safety-products

StatusBus message from slave contains 3 information bits.

- Info status
- Reserved
- Health

What the Health bit is representing depends on type of slave.

- Eden: Eva is on detection distance limit.

To reset the factory settings again

1. With the FIXA; set the StatusBus address to 0.
- Or:
2. With Pluto Manager;
 - A. Set the StatusBus address to 0.
 - B. Remove master connection to pin5 before the StatusBus is checked via Pluto Manager (Eva removed from Adam), otherwise the unit will be addressed again.
 - C. Power cycle.

Note! StatusBus signal can only be detected by Adam DYN-Status when in safe state. I.e. Eva is out of detection distance from Adam that will set pin-5 low.

Note! When the Pluto is acting as a StatusBus Master the operation requires system OS 3.6.1 or higher. The programming tool Pluto Manager must be of version 2.26 or higher.

7 LED indication

The non-safe status LED on Adam shows the status of the Eden sensor and the output status as follows:

LED on Adam	Description	Safety circuit
Green	Valid Eva within range	Closed
Flashing green	Valid Eva within range, waiting for reset	Open
Flashing red/green	Valid Eva within range, no valid in signal	Open
Red	Valid Eva out of range	Open
Fast flashing green	Valid Eva is within 2 mm from maximum detection distance	Closed
Fast flashing red	Fail safe mode	Open
Flashing red	No Eva programmed	Open

When Adam DYN-Status operates in StatusBus mode, the following LED statuses are also possible:

LED on Adam StatusBus	Description	
Double flash, red 0.11/0.2/0.11/0.67 s, on/off/on/off	Sensor in StatusBus mode, off. "Ready slave" Address 0.	Eva is not within detection distance during addressing.
Double flash, green 0.11/0.2/0.11/0.67 s, on/off/on/off	Sensor in StatusBus mode, on. Address 0.	Addressed from 1–30 to 0. Eva within detection distance.
Off for 5 s, then flickering flash 0.07/1.9 s, on/off	Sensor in StatusBus mode, on. Teach mode.	The flashing usually lasts for 1-4 seconds during the addressing (teach) process.
Burst with stress flash. Burst cycle: 0.8/0.4 s, on/off	At the command from Pluto Manager.	Visible sensor identification.

8 Maintenance

Maintenance precautions

Maintenance shall be done in accordance with a risk assessment for the individual application.

 **Warning!** The safety functions and the mechanics must be tested regularly, at least once every year to confirm that all the safety functions are working properly.

 **Warning!** In case of breakdown or damage to the product, contact ABB. Do not try to repair the product. It might accidentally cause permanent damage, impairing the safety of the device and in turn lead to serious injury to personnel.

Troubleshooting

LED on Adam	Expected causes of faults	Corrective actions
Lights red	Eva away from Adam	Move Eva closer to Adam
	Metal between Adam and Eva	Remove the metal
	+24 VDC short to pin-2 (no DYNlink signal)	Check the DYNlink input and cabling
No light	Loss of power supply	Check +24 VDC / 0 VDC power supply
Lights green (but no DYNlink output detected)	Defect DYNlink signal input to unit	Check the DYNlink input or the unit before in the safety circuit.
Lights green/red (flashing)	No DYNlink input (Eva in position with Adam)	Check the unit before in the safety circuit (make it active).
Fast flashing red	Fail safe mode	<ol style="list-style-type: none"> 1. Power cycle 2. Erase and reattach code 3. Replace unit
Fast flashing green	At end of detection distance	Move Eva closer to Adam.

 **Warning!** Never bypass the safety circuit using Tina 1A or any other solution. Always replace a defect unit with a new one.

9 Compatibility with analog models of Eden

Eden DYN is designed to be compatible with analog models of Eden, still there are differences. The compatibility of Eden DYN and analog Eden are limited to:

Eden DYN uses a processor based digital technique and the analog Eden uses analog technique. This difference in technology creates some differences in the processing of the DYNlink signal. This can make the two models to behave different in environments with for example high interferences and magnetic fields.

It is possible to mix analog Eden with Eden DYN in the same safety circuit with these limitations:

- If the safety circuit includes two Eden or more in parallel, all analog Eden must be replaced by Eden DYN.
- It is not possible to use an analog Adam with a digital Eva.
- It is not possible to use an analog Eva with a digital Adam DYN.
- The info output switches from +24 V to 0 V on analog models of Eden. Eden DYN has only a +24 V/Info output.
- When mounting close to metal the detection distance between Adam and Eva will be shorter for Eden DYN compared to analog models of Eden

Note! It is possible to connect an Adam DYN Info to the safety circuit of a StatusBus system if pin-5 is disconnected with e.g. a M12-3A.

Note! It is possible to connect an Adam DYN Reset to the safety circuit of a StatusBus system, if pin-5 is disconnected with e.g. a Smile 12RF or a M12-3A.

Eden DYN - Current



Eden Analog - Former models



10 Model overview

Model	Product ID	Description
Adam DYN-Info M12-5	2TLA020051R5100	Pin 5: Information
Adam C DYN-Info M12-5	2TLA020051R5101	Pin 5: Information
Adam DYN-Reset M12-5	2TLA020051R5300	Pin 5: Reset/Indication
Adam DYN-Status M12-5	2TLA020051R5200	Pin 5: Information/StatusBus
Eva General code	2TLA020046R0800	General code
Eva C General code	2TLA020046R0801	General code
Eva Unique code	2TLA020046R0900	Unique code
Eva C Unique code	2TLA020046R0901	Unique code

Accessories

Accessories, spare parts and cables are ordered separately. For a complete list, see the

[ABB safety products catalog](#).

11 Technical data

Manufacturer	
Address	ABB Electrification Sweden AB SE-721 61 Västerås Sweden
Power supply	
Rated operating voltage	+24 VDC +15 % -40 % Use SELV/PELV
Current consumption	30 mA at 24 VDC 35 mA at 18 VDC (45 mA at 12 VDC)
Reset indication lamp output	30 mA max on pin 5 (Adam DYN-Reset)
Information output	15 mA max on pin 5 (Adam DYN-Info)
Electrical data	
Voltage drop (DYNlink out)	2.5V@25mA
OFF-state current (DYNlink out)	<3µA
Transponder frequency	4 MHz
Max. switching frequency	1 Hz
Environmental data	
EMC	EN 60947-5-3:2013
Ambient temperature	Operation: -40...+70 °C Storage: -40...+70 °C
Humidity range	Eden: 35 to 85 % (with no icing or condensation) Eden C: 35 to 95 %
Times	
Switch-on delay power on	2 s
Response time at activation	<100 ms
Response time at deactivation	<30 ms
Risk time	<30 ms
Useful lifetime / mission time	20 years
Mechanical data	
Protection class	IP67/IP69K
Enclosure Type Rating:	Type 1
Material	Housing: Polybutylene terephthalate (PBT) Molding: Epoxy
Connector	M12 5-pole male Torque: 0.6 Nm
Mounting	Screw torque: 1.0 Nm
Weight	Adam: 80 g Eva: 70 g
Color	Yellow, grey text
Assured release distance (S_{ar})	25 mm
Assured operating distance (S_{ao})	10 mm
Rated operating distance (S_n)	15 +/- 2 mm
Hysteresis	1-2 mm

Information for use in USA / Canada																			
Enclosure	Type 1, 4, 4x																		
Intended use	Applications according to NFPA 79																		
Power source	<p>Only suitable for use in a limited voltage / current circuitry. The limited voltage / current source must comply with one of the following:</p> <p>a) An isolating device such that the maximum open circuit voltage potential available to the circuit is not more than +24 VDC and the current is limited to a value not exceeding 8 A measured after 1 min of operation.</p> <p>or</p> <p>b) A suitable isolating source in conjunction with a fuse in accordance with UL248. The fuse shall be rated max. 4 A and be installed in the +24 VDC power supply to the device to limit the available current.</p>																		
Cable assemblies	Any listed (CYJV/7), M12, 4-pin or 5-pin, A-coding mating connector. Cord provided shall be 24 AWG (0.2 mm ²) minimum when one end is provided with leads for connection to the source, 30 AWG (0.05 mm ²) minimum when connectors are provided on both ends.																		
Conductor size	<p>Maximum ampere ratings of the overcurrent protection:</p> <table border="1"> <thead> <tr> <th>AWG</th> <th>(mm²)</th> <th>Ampere</th> </tr> </thead> <tbody> <tr> <td>22</td> <td>(0.32)</td> <td>3</td> </tr> <tr> <td>24</td> <td>(0.20)</td> <td>2</td> </tr> <tr> <td>26</td> <td>(0.13)</td> <td>1</td> </tr> <tr> <td>28</td> <td>(0.08)</td> <td>0.8</td> </tr> <tr> <td>30</td> <td>(0.05)</td> <td>0.5</td> </tr> </tbody> </table>	AWG	(mm ²)	Ampere	22	(0.32)	3	24	(0.20)	2	26	(0.13)	1	28	(0.08)	0.8	30	(0.05)	0.5
AWG	(mm ²)	Ampere																	
22	(0.32)	3																	
24	(0.20)	2																	
26	(0.13)	1																	
28	(0.08)	0.8																	
30	(0.05)	0.5																	
Directives / Harmonized Standards																			
EN 61508:2010	SIL3, PFH _D = 4.5 x 10 ⁻⁹																		
EN 62061:2021	SIL3																		
EN ISO 13849-1:2015	PL e, category 4																		
EN ISO 14119:2013	Type 4, high level coded, (Eva Unique code) Type 4, low level coded, (Eva General code)																		
Certificates	TÜV Süd, cULus																		

Guideline for chemical resistance

Chemicals	Eden DYN
Hydrocarbons	
aliphatic	Good
aromatic	Good
halogenated	
- fully	Poor/Fair
- partly	Poor
Alcohols	Good
Phenols	Poor
Ketones	Fair/ Good
Amines	Not tested
Esters	Fair/ Good
Ethers	Good
Acids	
inorganic	Good
organic	Fair
oxidizing	Poor
Alkalis	Poor
Automotive fluids	
Greases (non-reactive organic esters)	Very good
Oils (unsaturated aliphatic mixtures)	Very good
Waxes (heavy oils)	Very good
Petrol	Very good
Cooling liquid (glycol)	Very good
Brake fluid (heavy alcohol)	Good
Detergents, cleaners	Good
Water	
hot (> 80°C)	Poor
Environmental	
UV	Good

Very good

- Found unaffected in its performance with regard to time, temperature and stress.

Good

- Found acceptable in normal exposure.
- Long term exposure may result in minor loss of properties.
- Higher temperatures may result in major loss of properties.

Fair

- Only for short exposures at lower temperatures or when loss of mechanical properties is not critical.

Poor

- Will result in failure or severe degradation.

Eden dimensions

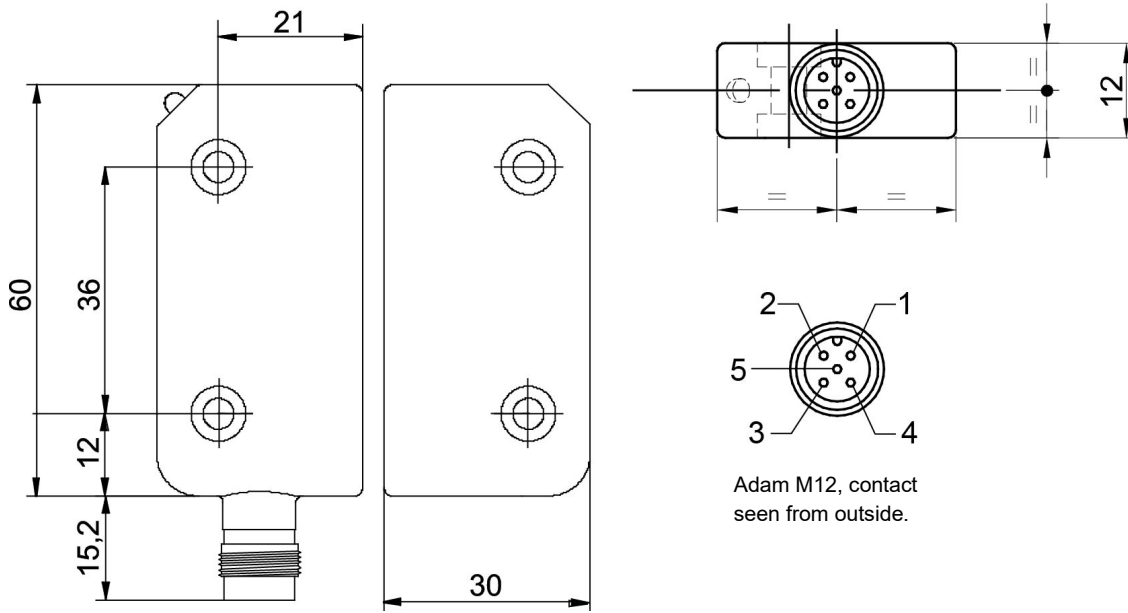

All dimensions in millimeters.

CAD model

For CAD models please visit new.abb.com/low-voltage/products/safety-products

12 Declaration of conformity



EC Declaration of conformity

(according to 2006/42/EC, Annex 2A)

We ABB Electrification Sweden AB SE-721 61 Västerås Sweden declare that the safety components of ABB Electrification Sweden AB manufacture with type designations and safety functions as listed below, is in conformity with the Directives

2006/42/EC – Machinery
2014/30/EU – EMC
2011/65/EU – RoHS II + 2015/863

Authorised to compile the technical file ABB Electrification Sweden AB SE-721 61 Västerås Sweden

Product

Non-contact safety sensor
Eden Dyn (Adam, Eva)

Certificate

Z10 049833 0035 Rev. 01

Certification Body TÜV Süd Product Service GmbH
Ridlerstrasse 65
80339 München
Germany

Used harmonized standards EN ISO 12100:2010, EN ISO 13849-1:2015,
EN 62061:2021, EN 60204-1:2018, EN ISO 14119:2013,
EN 60947-5-3:2013, EN 60664-1:2007, EN 61000-6-2:2005,
EN 61000-6-4:2007

Other used standards EN 61508:2010

Alessandro Pelandi
R&D Manager
Västerås 2023-04-20

abb.com/lowvoltage

Original



Declaration of conformity

(according to 2008 No 1597)

We ABB Electrification Sweden AB
SE-721 61 Västerås
Sweden

declare that the safety components of ABB Electrification Sweden AB manufacture with type designations and safety functions as listed below, is in conformity with UK Statutory Instruments (and their amendments)

2008 No 1597 – Supply of Machinery (Safety) Regulations (MD)
2016 No. 1091 – Electromagnetic Compatibility Regulations (EMC)
2012 No 3032 – Restriction of the Use of Certain Hazardous Substances in Electrical and Electronic Equipment Regulations (RoHS)

Authorized representative

ABB Limited
Tower Court
Coventry
CV6 5NX
United Kingdom

Authorised to compile the technical file

ABB Limited
Tower Court
Coventry
CV6 5NX
United Kingdom

Product

Non-contact safety sensor
Eden DYN (Adam, Eva)

Used designated standards

EN ISO 12100:2010, EN ISO 13849-1:2015, EN 62061:2005/A2:2015,
EN 60204-1:2018, EN ISO 14119:2013, EN 60947-5-3:2013,
EN 60664-1:2007, EN 61000-6-2:2005/AC:2005,
EN 61000-6-4:2007/A1:2011

Other used standards

EN 61508:2010

Magnus Backman
R&D Manager
Västerås 2021-03-26

abb.com/lowvoltage

Original