

Siemens
EcoTech



Circuit breaker size S0 for starter combination Rated current 32 A N-release 400 A screw terminal Standard switching capacity



product brand name	SIRIUS
product designation	Circuit breaker
design of the product	For starter combinations
product type designation	3RV2
General technical data	
size of the circuit-breaker	S0
size of contactor can be combined company-specific	S00, S0
product extension auxiliary switch	Yes
power loss [W] for rated value of the current	
• at AC in hot operating state	13.25 W
• at AC in hot operating state per pole	4.4 W
insulation voltage with degree of pollution 3 at AC rated value	690 V
surge voltage resistance rated value	6 kV
shock resistance according to IEC 60068-2-27	25g / 11 ms
mechanical service life (operating cycles)	
• of the main contacts typical	100 000
• of auxiliary contacts typical	100 000
electrical endurance (operating cycles) typical	100 000
reference code according to IEC 81346-2	Q
Substance Prohibitance (Date)	10/01/2009
SVHC substance name	Lead - 7439-92-1 Lead titanium zirconium oxide - 12626-81-2
Weight	0.376 kg
Ambient conditions	
installation altitude at height above sea level maximum	2 000 m
ambient temperature	
• during operation	-20 ... +60 °C
• during storage	-50 ... +80 °C
• during transport	-50 ... +80 °C
relative humidity during operation	10 ... 95 %
Environmental footprint	
Environmental Product Declaration(EPD)	Yes
global warming potential [CO2 eq] total	75.078 kg
global warming potential [CO2 eq] during manufacturing	2.68 kg
global warming potential [CO2 eq] during sales	0.143 kg
global warming potential [CO2 eq] during operation	72.7 kg
global warming potential [CO2 eq] after end of life	-0.445 kg

Siemens Eco Profile (SEP)	Siemens EcoTech
Main circuit	
number of poles for main current circuit	3
type of voltage for main current circuit	AC
operating voltage	
• rated value	20 ... 690 V
• at AC-3 rated value maximum	690 V
• at AC-3e rated value maximum	690 V
operating frequency rated value	50 ... 60 Hz
operational current rated value	32 A
operational current	
• at AC-3 at 400 V rated value	32 A
• at AC-3e at 400 V rated value	32 A
operating power	
• at AC-3	
— at 230 V rated value	7.5 kW
— at 400 V rated value	15 kW
— at 500 V rated value	18.5 kW
— at 690 V rated value	30 kW
• at AC-3e	
— at 230 V rated value	7.5 kW
— at 400 V rated value	15 kW
— at 500 V rated value	18.5 kW
— at 690 V rated value	30 kW
operating frequency	
• at AC-3 maximum	15 1/h
• at AC-3e maximum	15 1/h
Auxiliary circuit	
type of voltage for auxiliary and control circuit	AC/DC
number of NC contacts for auxiliary contacts	0
number of NO contacts for auxiliary contacts	0
number of CO contacts for auxiliary contacts	0
Protective and monitoring functions	
product function	
• ground fault detection	No
• phase failure detection	No
maximum short-circuit current breaking capacity (I_{cu})	
• at AC at 240 V rated value	100 kA
• at AC at 400 V rated value	55 kA
• at AC at 500 V rated value	10 kA
• at AC at 690 V rated value	4 kA
operating short-circuit current breaking capacity (I_{cs}) at AC	
• at 240 V rated value	100 kA
• at 400 V rated value	25 kA
• at 500 V rated value	5 kA
• at 690 V rated value	2 kA
response value current of instantaneous short-circuit trip unit	400 A
UL/CSA ratings	
full-load current (FLA) for 3-phase AC motor	
• at 480 V rated value	32 A
• at 600 V rated value	32 A
yielded mechanical performance [hp]	
• for single-phase AC motor	
— at 110/120 V rated value	2 hp
— at 230 V rated value	5 hp
• for 3-phase AC motor	
— at 200/208 V rated value	7.5 hp
— at 220/230 V rated value	10 hp
— at 460/480 V rated value	20 hp
Short-circuit protection	

product function short circuit protection	Yes
design of the short-circuit trip	magnetic
design of the fuse link for IT network for short-circuit protection of the main circuit	
<ul style="list-style-type: none"> ● at 400 V ● at 500 V ● at 690 V 	gL/gG 63 A gL/gG 63 A gL/gG 63 A
Installation/ mounting/ dimensions	
mounting position	any
fastening method	screw and snap-on mounting onto 35 mm DIN rail according to DIN EN 60715
height	97 mm
width	45 mm
depth	97 mm
required spacing	
<ul style="list-style-type: none"> ● with side-by-side mounting at the side ● for grounded parts at 400 V <ul style="list-style-type: none"> — downwards — upwards — at the side ● for live parts at 400 V <ul style="list-style-type: none"> — downwards — upwards — at the side ● for grounded parts at 500 V <ul style="list-style-type: none"> — downwards — upwards — at the side ● for live parts at 500 V <ul style="list-style-type: none"> — downwards — upwards — at the side ● for grounded parts at 690 V <ul style="list-style-type: none"> — downwards — upwards — backwards — at the side — forwards ● for live parts at 690 V <ul style="list-style-type: none"> — downwards — upwards — backwards — at the side — forwards 	0 mm 30 mm 30 mm 9 mm 30 mm 30 mm 9 mm 30 mm 30 mm 9 mm 50 mm 50 mm 0 mm 30 mm 0 mm 50 mm 50 mm 0 mm 30 mm 0 mm
Connections/ Terminals	
type of electrical connection	
<ul style="list-style-type: none"> ● for main current circuit 	screw-type terminals
arrangement of electrical connectors for main current circuit	Top and bottom
type of connectable conductor cross-sections	
<ul style="list-style-type: none"> ● for main contacts <ul style="list-style-type: none"> — solid or stranded — finely stranded with core end processing ● for AWG cables for main contacts 	2x (1 ... 2.5 mm ²), 2x (2.5 ... 10 mm ²) 2x (1 ... 2.5 mm ²), 2x (2.5 ... 6 mm ²), 1x 10 mm ² 2x (16 ... 12), 2x (14 ... 8)
tightening torque	
<ul style="list-style-type: none"> ● for main contacts with screw-type terminals 	2 ... 2.5 N·m
design of screwdriver shaft	Diameter 5 to 6 mm
size of the screwdriver tip	Pozidriv size 2
design of the thread of the connection screw	
<ul style="list-style-type: none"> ● for main contacts 	M4
Safety related data	
product function suitable for safety function	Yes

suitability for use	
• safety-related switching on	No
• safety-related switching OFF	Yes
service life maximum	10 a
test wear-related service life necessary	Yes
proportion of dangerous failures	
• with low demand rate according to SN 31920	40 %
• with high demand rate according to SN 31920	50 %
B10 value with high demand rate according to SN 31920	5 000
failure rate [FIT] with low demand rate according to SN 31920	50 FIT
ISO 13849	
device type according to ISO 13849-1	3
overdimensioning according to ISO 13849-2 necessary	Yes
IEC 61508	
safety device type according to IEC 61508-2	Type A
T1 value	
• for proof test interval or service life according to IEC 61508	10 a
Electrical Safety	
protection class IP on the front according to IEC 60529	IP20
touch protection on the front according to IEC 60529	finger-safe, for vertical contact from the front
Display	
display version for switching status	Handle
Approvals Certificates	
General Product Approval	



[KC](#)



General Product Approval	Test Certificates	Maritime application
---------------------------------	--------------------------	-----------------------------



[Type Test Certificates/Test Report](#)

[Special Test Certificate](#)



Maritime application	other
-----------------------------	--------------



[Miscellaneous](#)



[Confirmation](#)

other	Railway	Environment
--------------	----------------	--------------------



[Special Test Certificate](#)

[Confirmation](#)



[Environmental Confirmations](#)

Further information

Information on the packaging

<https://support.industry.siemens.com/cs/ww/en/view/109813875>

Information- and Downloadcenter (Catalogs, Brochures,...)

<https://www.siemens.com/ic10>

Industry Mall (Online ordering system)

<https://mall.industry.siemens.com/mall/en/en/Catalog/product?mlfb=3RV2321-4EC10>

Cax online generator

<http://support.automation.siemens.com/WW/CAXorder/default.aspx?lang=en&mlfb=3RV2321-4EC10>

Service&Support (Manuals, Certificates, Characteristics, FAQs,...)

<https://support.industry.siemens.com/cs/ww/en/ps/3RV2321-4EC10>

Image database (product images, 2D dimension drawings, 3D models, device circuit diagrams, EPLAN macros, ...)

http://www.automation.siemens.com/bilddb/cax_de.aspx?mlfb=3RV2321-4EC10&lang=en

Characteristic: Tripping characteristics, I²t, Let-through current

<https://support.industry.siemens.com/cs/ww/en/ps/3RV2321-4EC10/char>

Further characteristics (e.g. electrical endurance, switching frequency)

<http://www.automation.siemens.com/bilddb/index.aspx?view=Search&mlfb=3RV2321-4EC10&objecttype=14&gridview=view1>

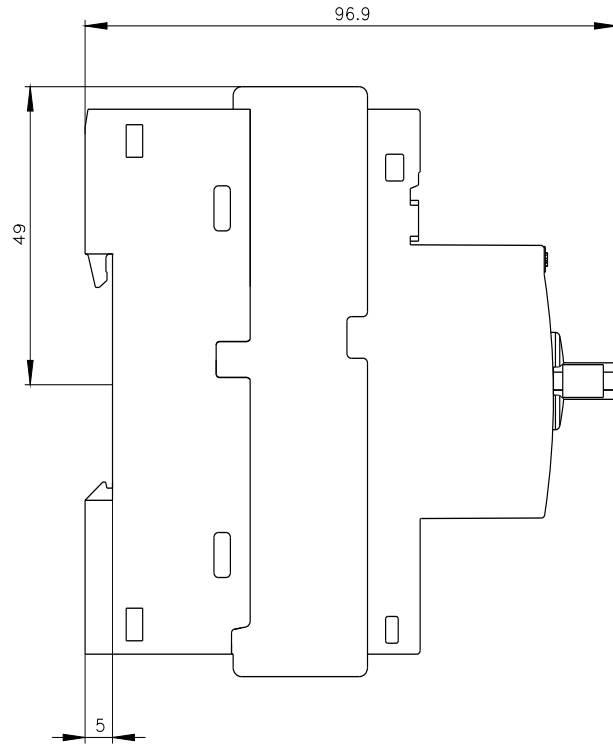
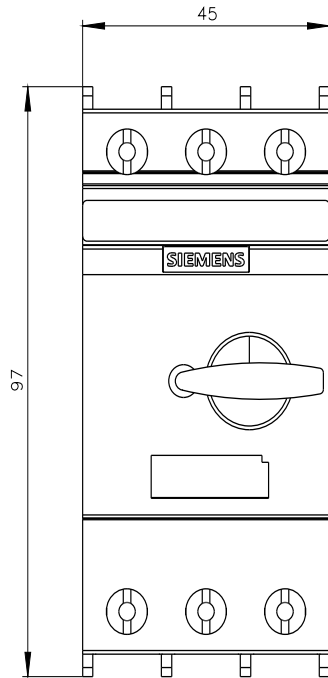

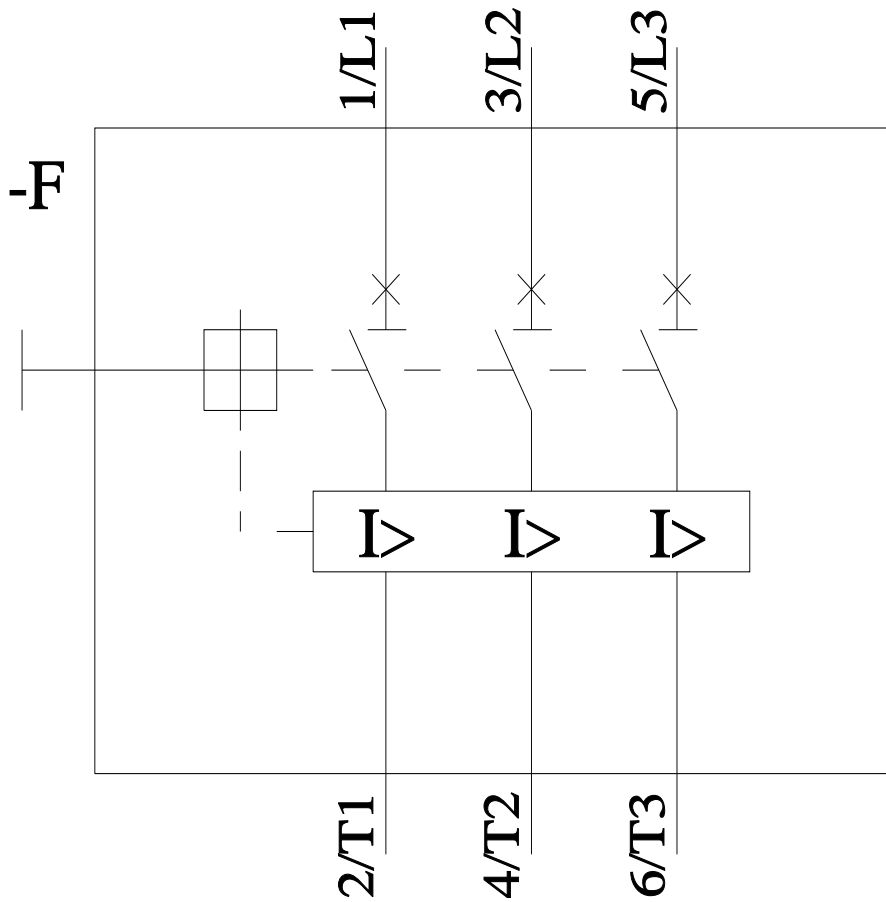

last modified:

5/16/2025 