



SIRIUS safety relay Basic unit Advanced series with time delay 5-300 s electronic enabling circuits 2 NO instantaneous 2 NO delayed  $U_s = 24\text{ V DC}$  screw terminal

<b>product brand name</b>	SIRIUS
<b>product category</b>	Safety relays
<b>product designation</b>	safety relays
<b>design of the product</b>	Solid-state enabling circuits
<b>product type designation</b>	3SK1
<b>product line</b>	Advanced basic unit
<b>Product Function</b>	
<b>product function parameterizable</b>	sensor floating / sensor non-floating, monitored start-up / automatic start, 1-channel / 2-channel sensor connection, cross-circuit detection, startup testing, antivalent sensors, 2-hand switches, time delay
<b>product function</b>	
<ul style="list-style-type: none"> <li>• automatic start</li> <li>• light barrier monitoring</li> <li>• protective door monitoring</li> <li>• magnetically operated switch monitoring NC-NO</li> <li>• magnetically operated switch monitoring NC-NC</li> <li>• laser scanner monitoring</li> <li>• light array monitoring</li> <li>• EMERGENCY OFF function</li> <li>• monitored start-up</li> <li>• pressure-sensitive mat monitoring</li> </ul>	<ul style="list-style-type: none"> <li>Yes</li> <li>Yes</li> <li>Yes</li> <li>Yes</li> <li>Yes</li> <li>Yes</li> <li>Yes</li> <li>Yes</li> <li>Yes</li> <li>No</li> </ul>
<b>suitability for interaction press control</b>	Yes
<b>suitability for operation device connector 3ZY12</b>	Yes
<b>suitability for use</b>	
<ul style="list-style-type: none"> <li>• monitoring of floating sensors</li> <li>• monitoring of non-floating sensors</li> <li>• position switch monitoring</li> <li>• EMERGENCY-OFF circuit monitoring</li> <li>• opto-electronic protection device monitoring</li> <li>• magnetically operated switch monitoring</li> <li>• safety switch</li> <li>• safety-related circuits</li> </ul>	<ul style="list-style-type: none"> <li>Yes</li> <li>Yes</li> <li>Yes</li> <li>Yes</li> <li>Yes</li> <li>Yes</li> <li>Yes</li> <li>Yes</li> </ul>
<b>General technical data</b>	
certificate of suitability UL approval	Yes
<b>product feature cross-circuit-proof</b>	Yes
<b>power loss [W] maximum</b>	2 W
<b>insulation voltage rated value</b>	50 V
<b>degree of pollution</b>	3
<b>overvoltage category</b>	3
<b>surge voltage resistance rated value</b>	800 V
protection class IP of the enclosure	IP20

<b>shock resistance</b>	10g / 11 ms
<b>vibration resistance according to IEC 60068-2-6</b>	5 ... 500 Hz: 0.75 mm
<b>operating frequency maximum</b>	2 000 1/h
<b>reference code according to IEC 81346-2</b>	F
<b>Substance Prohibitance (Date)</b>	11/05/2012
<b>SVHC substance name</b>	Lead - 7439-92-1 Lead monoxide (lead oxide) - 1317-36-8 2,2',6,6'-tetrabromo-4,4'-isopropylidenediphenol - 79-94-7 2-methyl-1-(4-methylthiophenyl)-2-morpholinopropan-1-one - 71868-10-5 6,6'-di-tert-butyl-2,2'-methylenedi-p-cresol - 119-47-1 Lead titanium zirconium oxide - 12626-81-2
<b>Weight</b>	0.2 kg
<b>Ambient conditions</b>	
installation altitude at height above sea level maximum	4 000 m; Derating, see Product Notification 109792701
<b>ambient temperature</b>	
• during operation	-25 ... +60 °C
• during storage	-40 ... +80 °C
relative humidity during operation	10 ... 95 %
air pressure according to SN 31205	900 ... 1 060 hPa
<b>Electromagnetic compatibility</b>	
<b>installation environment regarding EMC</b>	This product is suitable for Class A environments only. In household environments, this device can cause unwanted radio interference. The user is required to implement appropriate measures in this case.
<b>EMC emitted interference</b>	IEC 60947-5-1, Class A
<b>Safety related data</b>	
product function suitable for safety function	Yes
<b>safe state</b>	Safety outputs switched off
<b>test wear-related service life necessary</b>	No
<b>diagnostics test interval by internal test function maximum</b>	600 s
<b>stop category according to IEC 60204-1</b>	0 / 1
<b>IEC 62061</b>	
SIL Claim Limit (subsystem) according to EN 62061	3
<b>Safety Integrity Level (SIL)</b>	
• according to IEC 62061	SIL 3
• at single-channel evaluation according to IEC 62061	1
• at 2-channel evaluation according to IEC 62061	3
PFHD with high demand rate according to IEC 62061	1.5E-9 1/h
<b>ISO 13849</b>	
category according to EN ISO 13849-1	4
<b>performance level (PL)</b>	
• according to ISO 13849-1	PL e
• at single-channel evaluation according to ISO 13849-1	c
• at 2-channel evaluation according to ISO 13849-1	e
• for delayed release circuit according to ISO 13849-1	e
<b>category</b>	
• according to ISO 13849-1	4
• at 2-channel evaluation according to ISO 13849-1	4
<b>overdimensioning according to ISO 13849-2 necessary</b>	
	No
<b>IEC 61508</b>	
<b>Safety Integrity Level (SIL)</b>	
• according to IEC 61508	3
• for delayed release circuit according to IEC 61508	SIL3
• at single-channel evaluation according to IEC 61508	1
• at 2-channel evaluation according to IEC 61508	3
<b>safety device type according to IEC 61508-2</b>	Type B
<b>PFHD with high demand rate according to IEC 61508</b>	1.5E-9 1/h
<b>Average probability of failure on demand (PFDavg) with low demand rate acc. to IEC 61508</b>	7E-6 1/y
PFDavg with low demand rate according to IEC 61508	7E-6
<b>Safe failure fraction (SFF)</b>	99 %
<b>hardware fault tolerance</b>	
• according to IEC 61508	1
• at single-channel evaluation according to IEC 61508	0

<ul style="list-style-type: none"> <li>at 2-channel evaluation according to IEC 61508</li> </ul>	1
<b>T1 value</b>	
<ul style="list-style-type: none"> <li>of service life according to IEC 61508</li> </ul>	20 a
<ul style="list-style-type: none"> <li>for proof test interval or service life according to IEC 61508</li> </ul>	20 a
<b>Electrical Safety</b>	
<b>touch protection against electrical shock</b>	finger-safe
<b>Short-circuit protection</b>	
<b>design of the fuse link</b>	
<ul style="list-style-type: none"> <li>for short-circuit protection of the NO contacts of the relay outputs required</li> </ul>	not required
<b>Inputs</b>	
<b>design of input</b>	
<ul style="list-style-type: none"> <li>cascading input/functional switching</li> </ul>	Yes
<ul style="list-style-type: none"> <li>feedback input</li> </ul>	Yes
<ul style="list-style-type: none"> <li>start input</li> </ul>	Yes
pulse duration of the sensor input minimum	60 ms
number of sensor inputs 1-channel or 2-channel	1
<b>Outputs</b>	
<b>number of outputs as contact-less semiconductor switching element</b>	
<ul style="list-style-type: none"> <li>for signaling function <ul style="list-style-type: none"> <li>instantaneous contact</li> </ul> </li> </ul>	0
<ul style="list-style-type: none"> <li>safety-related <ul style="list-style-type: none"> <li>delayed switching</li> </ul> </li> </ul>	2
<ul style="list-style-type: none"> <li>instantaneous contact</li> </ul>	2
switching capacity current of semiconductor outputs at DC-13 at 24 V	2 A
<b>Times</b>	
<b>make time with automatic start</b>	
<ul style="list-style-type: none"> <li>at DC maximum</li> </ul>	85 ms
<b>make time with automatic start after power failure</b>	
<ul style="list-style-type: none"> <li>typical</li> </ul>	6 500 ms
<ul style="list-style-type: none"> <li>maximum</li> </ul>	6 500 ms
<b>make time with monitored start</b>	
<ul style="list-style-type: none"> <li>maximum</li> </ul>	85 ms
<b>backslide delay time after opening of the safety circuits typical</b>	40 ms
<b>adjustable OFF-delay time after opening of the safety circuits</b>	5 ... 300 s
<b>recovery time after opening of the safety circuits typical</b>	30 ms
<b>recovery time after power failure typical</b>	6.5 s
<b>pulse duration</b>	
<ul style="list-style-type: none"> <li>of the ON pushbutton input minimum</li> </ul>	0.15 s
<b>Control circuit/ Control</b>	
<b>type of voltage of the control supply voltage</b>	DC
<b>control supply voltage at DC rated value</b>	24 V
<b>operating range factor control supply voltage rated value of magnet coil at DC</b>	
<ul style="list-style-type: none"> <li>initial value</li> </ul>	0.8
<ul style="list-style-type: none"> <li>full-scale value</li> </ul>	1.2
<b>Installation/ mounting/ dimensions</b>	
<b>mounting position</b>	any
<b>fastening method</b>	screw and snap-on mounting
<b>height</b>	100 mm
<b>width</b>	22.5 mm
<b>depth</b>	121.6 mm
<b>required spacing</b>	
<ul style="list-style-type: none"> <li>for grounded parts at the side</li> </ul>	5 mm
<b>Connections/ Terminals</b>	
<b>type of electrical connection</b>	screw terminal
<b>wire length</b>	

<ul style="list-style-type: none"> <li>with Cu 1.5 mm<sup>2</sup> and 150 nF/km per sensor circuit maximum</li> </ul>	4 000 m
<b>type of connectable conductor cross-sections</b> <ul style="list-style-type: none"> <li>solid</li> <li>finely stranded with core end processing</li> <li>for AWG cables solid</li> <li>for AWG cables stranded</li> </ul>	1x (0.5 ... 2.5 mm <sup>2</sup> ), 2x (1.0 ... 1.5 mm <sup>2</sup> ) 1x (0.5 ... 2.5 mm <sup>2</sup> ), 2x (0.5 ... 1.0 mm <sup>2</sup> ) 1x (20 ... 14), 2x (18 ... 16) 1x (20 ... 16), 2x (20 ... 16)
<b>type of electrical connection plug-in socket</b>	No

#### Approvals Certificates

General Product Approval	EMV	Functional Safety
 CCC	 EG-Konf.	 UKCA
 EAC	 RCM	<a href="#">Type Examination Certificate</a>

Test Certificates	Maritime application	other	Environment
-------------------	----------------------	-------	-------------

<a href="#">Type Test Certificates/Test Report</a>	 LRS	 产品合格 QC PASS	<a href="#">Confirmation</a>
			<a href="#">Environmental Confirmations</a>

#### Further information

**Information on the packaging**  
<https://support.industry.siemens.com/cs/ww/en/view/109813875>

**Information for data generation and storage**  
<https://support.industry.siemens.com/cs/ww/en/view/109995012>

**Information- and Downloadcenter (Catalogs, Brochures,...)**  
<https://www.siemens.com/ic10>

**Industry Mall (Online ordering system)**  
<https://mall.industry.siemens.com/mall/en/en/Catalog/product?mlfb=3SK1122-1CB44>

**Cax online generator**  
<http://support.automation.siemens.com/WW/CAXorder/default.aspx?lang=en&mlfb=3SK1122-1CB44>

**Service&Support (Manuals, Certificates, Characteristics, FAQs,...)**  
<https://support.industry.siemens.com/cs/ww/en/ps/3SK1122-1CB44>

**Image database (product images, 2D dimension drawings, 3D models, device circuit diagrams, EPLAN macros, ...)**  
[http://www.automation.siemens.com/bilddb/cax\\_de.aspx?mlfb=3SK1122-1CB44&lang=en](http://www.automation.siemens.com/bilddb/cax_de.aspx?mlfb=3SK1122-1CB44&lang=en)

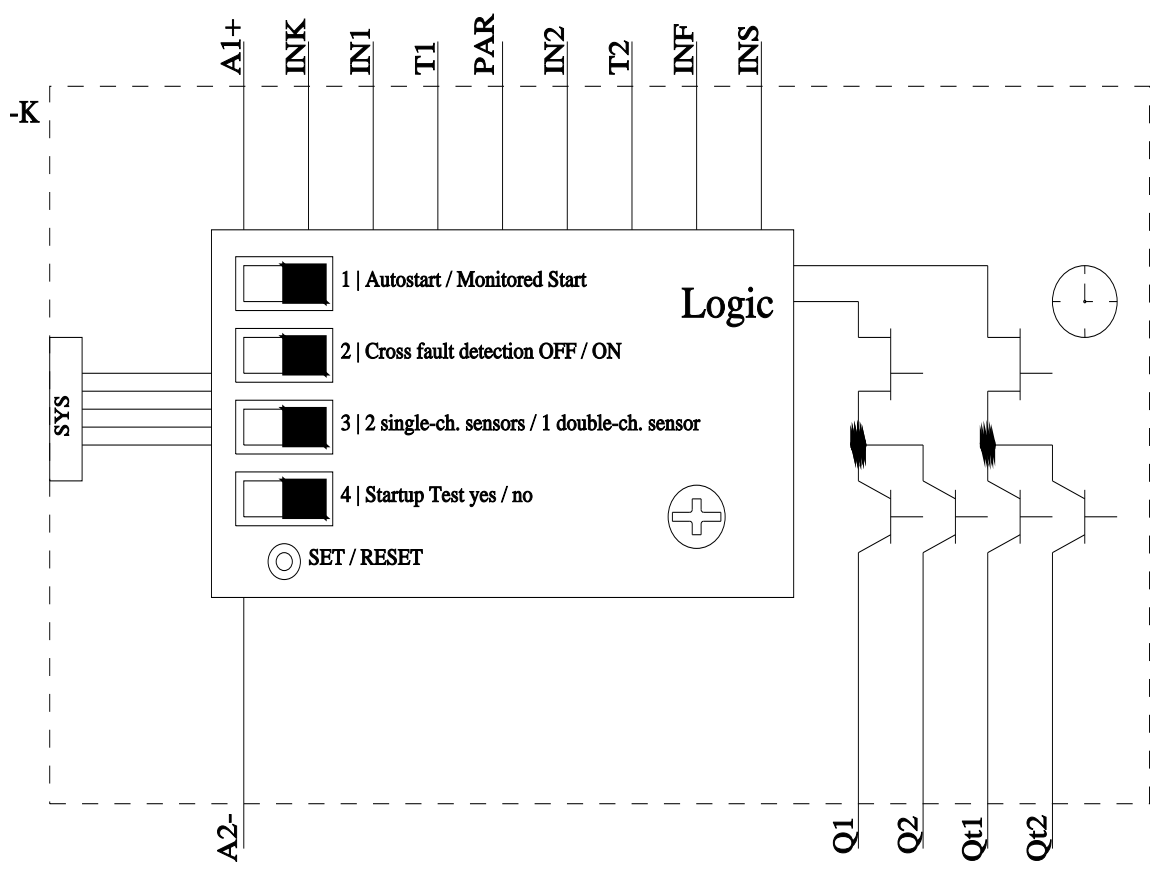
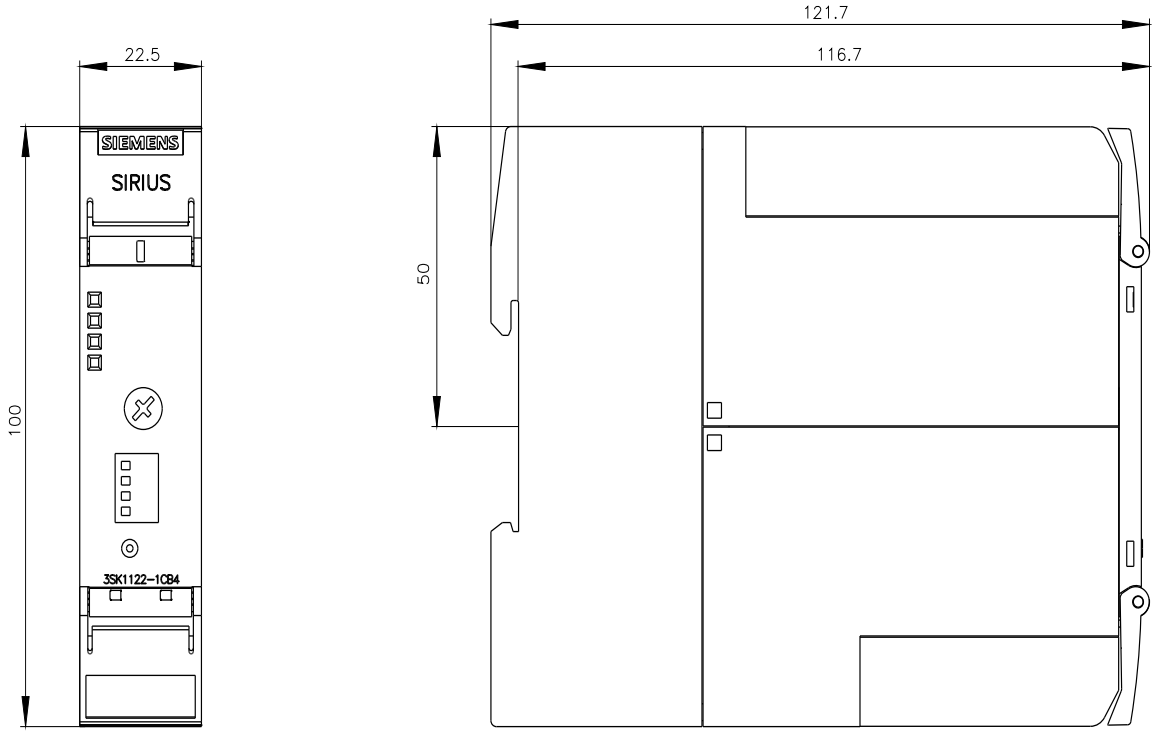

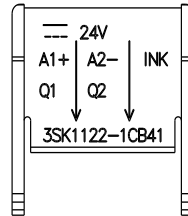
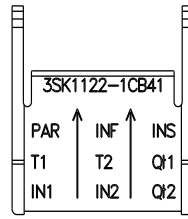
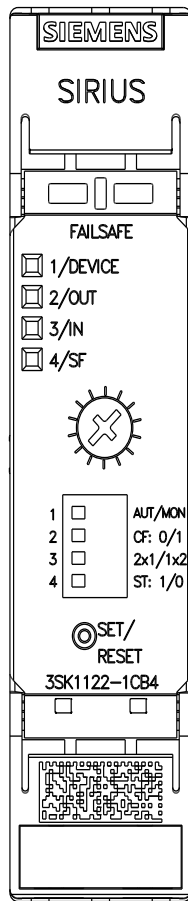

last modified:

9/8/2025