

Siemens
EcoTech



Circuit breaker size S2 for motor protection, CLASS 10 A-release 62...73 A N-release 949 A screw terminal increased switching capacity



product brand name	SIRIUS
product designation	Circuit breaker
design of the product	For motor protection
product type designation	3RV2
General technical data	
size of the circuit-breaker	S2
size of contactor can be combined company-specific	S2
product extension auxiliary switch	Yes
power loss [W] for rated value of the current	
• at AC in hot operating state	29.5 W
• at AC in hot operating state per pole	9.8 W
insulation voltage with degree of pollution 3 at AC rated value	690 V
surge voltage resistance rated value	6 kV
shock resistance according to IEC 60068-2-27	25g / 11 ms Sinus
mechanical service life (operating cycles)	
• of the main contacts typical	20 000
• of auxiliary contacts typical	20 000
electrical endurance (operating cycles) typical	20 000
reference code according to IEC 81346-2	Q
Substance Prohibitance (Date)	03/01/2017
SVHC substance name	Lead - 7439-92-1 Lead titanium zirconium oxide - 12626-81-2
Weight	1.17 kg
Ambient conditions	
installation altitude at height above sea level maximum	2 000 m
ambient temperature	
• during operation	-20 ... +60 °C
• during storage	-50 ... +80 °C
• during transport	-50 ... +80 °C
relative humidity during operation	10 ... 95 %
Environmental footprint	
Environmental Product Declaration(EPD)	Yes
global warming potential [CO2 eq] total	239.877 kg
global warming potential [CO2 eq] during manufacturing	12.8 kg
global warming potential [CO2 eq] during sales	0.477 kg
global warming potential [CO2 eq] during operation	230 kg
global warming potential [CO2 eq] after end of life	-3.4 kg

Siemens Eco Profile (SEP)	Siemens EcoTech
Main circuit	
number of poles for main current circuit	3
adjustable current response value current of the current-dependent overload release	62 ... 73 A
type of voltage for main current circuit	AC
operating voltage <ul style="list-style-type: none"> • rated value • at AC-3 rated value maximum 	20 ... 690 V 690 V
operating frequency rated value	50 ... 60 Hz
operational current rated value	73 A
operational current <ul style="list-style-type: none"> • at AC-3 at 400 V rated value 	73 A
operating power <ul style="list-style-type: none"> • at AC-3 <ul style="list-style-type: none"> — at 230 V rated value — at 400 V rated value — at 500 V rated value — at 690 V rated value 	22 kW 37 kW 45 kW 55 kW
operating frequency <ul style="list-style-type: none"> • at AC-3 maximum 	15 1/h
Auxiliary circuit	
type of voltage for auxiliary and control circuit	AC/DC
number of NC contacts for auxiliary contacts	0
number of NO contacts for auxiliary contacts	0
number of CO contacts for auxiliary contacts	0
Protective and monitoring functions	
product function <ul style="list-style-type: none"> • ground fault detection • phase failure detection 	No Yes
trip class	CLASS 10
design of the overload release	thermal
maximum short-circuit current breaking capacity (I _{cu}) <ul style="list-style-type: none"> • at AC at 240 V rated value • at AC at 400 V rated value • at AC at 500 V rated value • at AC at 690 V rated value 	100 kA 100 kA 10 kA 6 kA
operating short-circuit current breaking capacity (I _{cs}) at AC <ul style="list-style-type: none"> • at 240 V rated value • at 400 V rated value • at 500 V rated value • at 690 V rated value 	100 kA 50 kA 8 kA 4 kA
response value current of instantaneous short-circuit trip unit	949 A
UL/CSA ratings	
full-load current (FLA) for 3-phase AC motor <ul style="list-style-type: none"> • at 480 V rated value • at 600 V rated value 	65 A 62 A
yielded mechanical performance [hp] <ul style="list-style-type: none"> • for 3-phase AC motor <ul style="list-style-type: none"> — at 200/208 V rated value — at 220/230 V rated value — at 460/480 V rated value — at 575/600 V rated value 	20 hp 25 hp 50 hp 60 hp
Short-circuit protection	
product function short circuit protection	Yes
design of the short-circuit trip	magnetic
design of the fuse link for IT network for short-circuit protection of the main circuit <ul style="list-style-type: none"> • at 240 V • at 400 V • at 500 V 	none required 160 125

• at 690 V	100
Installation/ mounting/ dimensions	
mounting position	any
fastening method	screw and snap-on mounting onto 35 mm DIN rail according to DIN EN 60715
height	140 mm
width	55 mm
depth	149 mm
required spacing	
• with side-by-side mounting at the side	0 mm
• for grounded parts at 400 V	
— downwards	50 mm
— upwards	50 mm
— at the side	10 mm
• for live parts at 400 V	
— downwards	50 mm
— upwards	50 mm
— at the side	10 mm
• for grounded parts at 500 V	
— downwards	50 mm
— upwards	50 mm
— at the side	10 mm
• for live parts at 500 V	
— downwards	50 mm
— upwards	50 mm
— at the side	10 mm
• for grounded parts at 690 V	
— downwards	50 mm
— upwards	50 mm
— at the side	10 mm
• for live parts at 690 V	
— downwards	50 mm
— upwards	50 mm
— at the side	10 mm
Connections/ Terminals	
type of electrical connection	
• for main current circuit	screw-type terminals
arrangement of electrical connectors for main current circuit	Top and bottom
type of connectable conductor cross-sections	
• for main contacts	
— solid or stranded	2x (1 ... 35 mm ²), 1x (1 ... 50 mm ²)
— finely stranded with core end processing	2x (1 ... 25 mm ²), 1x (1 ... 35 mm ²)
• for AWG cables for main contacts	2x (18 ... 2), 1x (18 ... 1)
tightening torque	
• for main contacts with screw-type terminals	3 ... 4.5 N·m
design of screwdriver shaft	Diameter 5 to 6 mm
size of the screwdriver tip	Pozidriv size 2
design of the thread of the connection screw	
• for main contacts	M6
Safety related data	
product function suitable for safety function	Yes
suitability for use	
• safety-related switching on	No
• safety-related switching OFF	Yes
service life maximum	10 a
test wear-related service life necessary	Yes
proportion of dangerous failures	
• with low demand rate according to SN 31920	40 %
• with high demand rate according to SN 31920	50 %
B10 value with high demand rate according to SN 31920	5 000
failure rate [FIT] with low demand rate according to SN	50 FIT

31920	
ISO 13849	
device type according to ISO 13849-1	3
overdimensioning according to ISO 13849-2 necessary	Yes
IEC 61508	
safety device type according to IEC 61508-2	Type A
T1 value	10 a
• for proof test interval or service life according to IEC 61508	
Electrical Safety	
protection class IP on the front according to IEC 60529	IP20
touch protection on the front according to IEC 60529	finger-safe, for vertical contact from the front
Display	
display version for switching status	Handle
Approvals Certificates	
General Product Approval	



[KC](#)



General Product Approval	For use in hazardous locations	Test Certificates	Maritime application
--------------------------	--------------------------------	-------------------	----------------------



[Type Test Certificates/Test Report](#)

[Special Test Certificate](#)



Maritime application	other
----------------------	-------



[Miscellaneous](#)

other	Railway	Environment
-------	---------	-------------



[Confirmation](#)



[Special Test Certificate](#)

[Confirmation](#)



Environment



[Environmental Confirmations](#)

Further information

Information on the packaging

<https://support.industry.siemens.com/cs/ww/en/view/109813875>

Information for data generation and storage

<https://support.industry.siemens.com/cs/ww/en/view/109995012>

Information- and Downloadcenter (Catalogs, Brochures,...)

<https://www.siemens.com/ic10>

Industry Mall (Online ordering system)

<https://mall.industry.siemens.com/mall/en/en/Catalog/product?mlfb=3RV2032-4KA10>

Cax online generator

<http://support.automation.siemens.com/WW/CAXorder/default.aspx?lang=en&mlfb=3RV2032-4KA10>

Service&Support (Manuals, Certificates, Characteristics, FAQs,...)

<https://support.industry.siemens.com/cs/ww/en/ps/3RV2032-4KA10>

Image database (product images, 2D dimension drawings, 3D models, device circuit diagrams, EPLAN macros, ...)

http://www.automation.siemens.com/bilddb/cax_de.aspx?mlfb=3RV2032-4KA10&lang=en

Characteristic: Tripping characteristics, I²t, Let-through current

<https://support.industry.siemens.com/cs/ww/en/ps/3RV2032-4KA10/char>

Further characteristics (e.g. electrical endurance, switching frequency)

<http://www.automation.siemens.com/bilddb/index.aspx?view=Search&mlfb=3RV2032-4KA10&objecttype=14&gridview=view1>

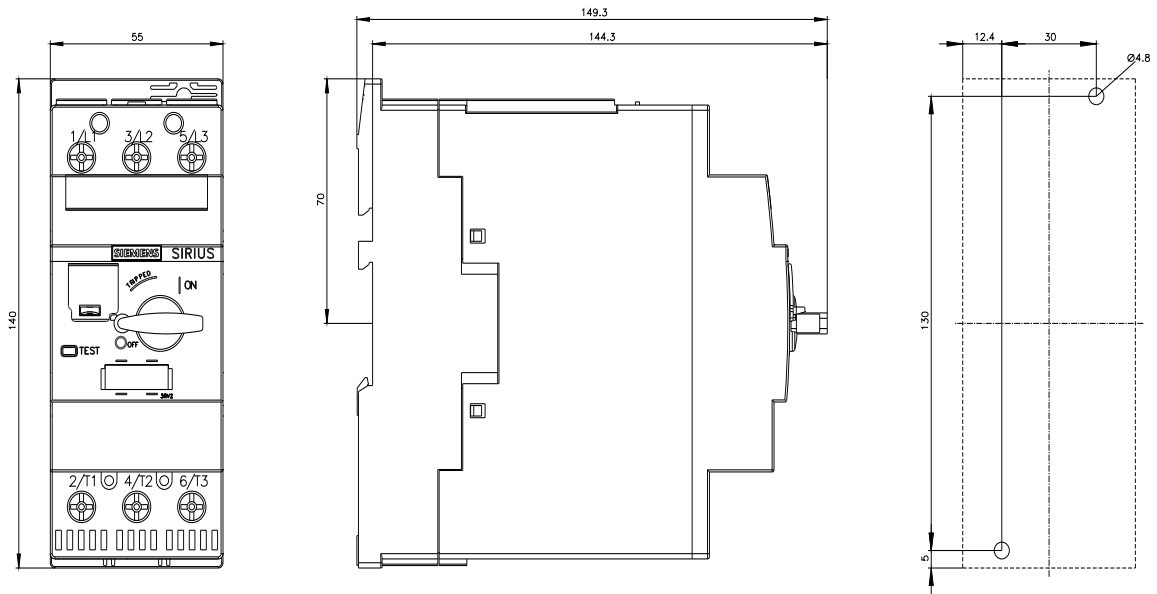

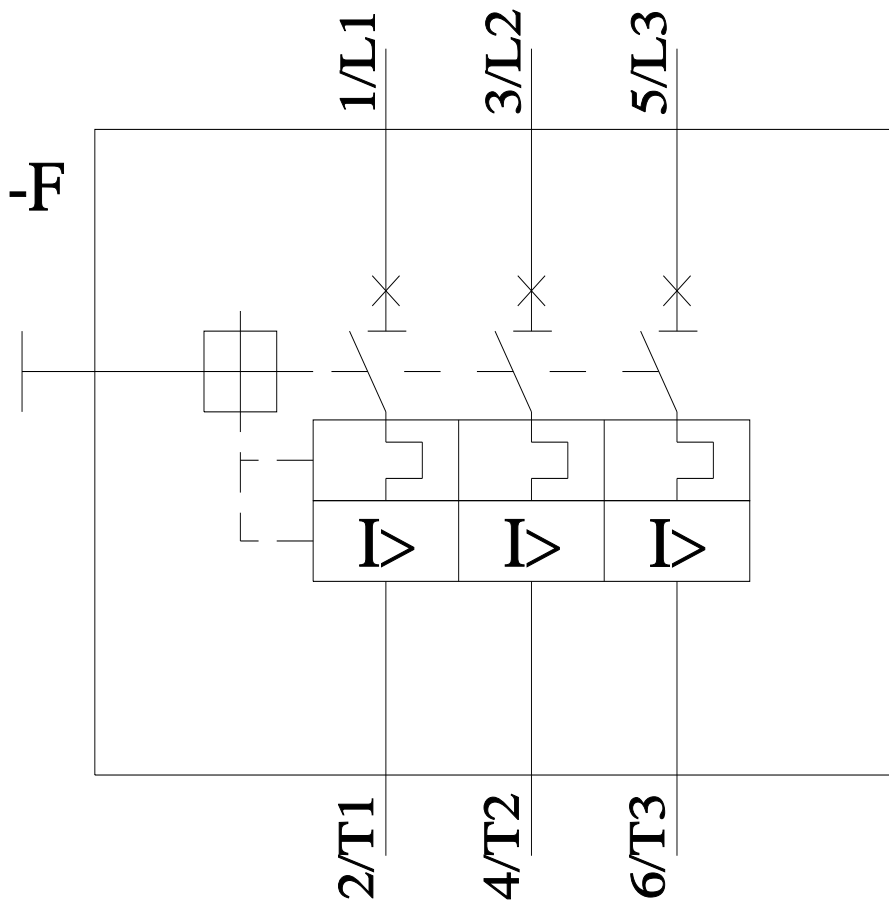

last modified:

5/16/2025 