

ATSU01N222LT

soft starter for asynchronous motor, Altistart U01, TeSys U, ATSU01, 22A, 200 to 480V, 4 to 11kW



Main

| | |
|------------------------------|---|
| Range of Product | Altistart U01 and TeSys U |
| Product or Component Type | Soft starter |
| Product destination | Asynchronous motors |
| Product Specific Application | Simple machine |
| Device short name | ATSU01 |
| Phase | 3 phase |
| [Us] rated supply voltage | 200...480 V - 10...10 % |
| Motor power kW | 11 KW, 3 phase 400 V 4 KW, 3 phase 230 V 7.5 KW, 3 phase 400 V 5.5 kW, 3 phase 230 V |
| Maximum Horse Power Rating | 5 Hp, 3 phase 230 V 7.5 Hp, 3 phase 230 V 10 Hp, 3 phase 460 V 15 hp, 3 phase 460 V |
| IcL starter rating | 22 A |
| Utilisation category | AC-53B EN/IEC 60947-4-2 |
| Current consumption | 100 mA |
| Type of start | Start with voltage ramp |
| Power dissipation in W | 2.5 W at full load and at end of starting 222.5 W in transient state |

Complementary

| | |
|------------------------------|--|
| Assembly style | With heat sink |
| Function Available | Integrated bypass |
| Supply voltage limits | 180...528 V |
| Supply frequency | 50...60 Hz - 5...5 % |
| Network Frequency | 47.5...63 Hz |
| Output voltage | <= power supply voltage |
| [Uc] control circuit voltage | 24 V DC +/- 10 % |
| Starting time | 1 s / 100 5 s / 20 10 s / 10 Adjustable from 1 to 10 s |
| Deceleration time symb | Adjustable from 1 to 10 s |
| Starting torque | 30...80 % of starting torque of motor connected directly on the line supply |
| Discrete input type | Logic LI1, LI2, BOOST) stop, run and boost on start-up functions <= 8 mA 27 kOhm |
| Discrete input voltage | 24...40 V |
| Input output isolation | Galvanic between power and control |
| Discrete input logic | Positive LI1, LI2, BOOST < 5 V <= 0.2 mA > 13 V, >= 0.5 mA |
| Discrete output current | 2 A DC-13 3 A AC-15 |
| Discrete output type | Open collector logic LO1 end of starting signal Relay outputs R1A, R1C NO |
| Discrete output voltage | 24 V 6...30 V) open collector logic |
| Minimum switching current | 10 mA 6 V DC relay outputs |

| | |
|---------------------------|--|
| Maximum switching current | Relay outputs 2 A 30 V DC cos phi = 0.5 20 ms inductive Relay outputs 2 A 250 V AC AC-15 cos phi = 0.5 20 ms inductive |
| Maximum switching voltage | 440 V relay outputs |
| Display type | 1 LED Green)starter powered up 1 LED Yellow)nominal voltage reached |
| Tightening torque | 16.8...22.1 Lbf.In (1.9...2.5 N.m) 4.4 lbf.in (0.5 N.m) |
| Electrical connection | 4 mm screw clamp terminal - rigid 1 1...10 mm ² AWG 8 power circuit Screw connector - rigid without cable end 1 0.5...2.5 mm ² AWG 14 control circuit 4 mm screw clamp terminal - rigid 2 1...6 mm ² AWG 10 power circuit Screw connector - rigid 2 0.5...1 mm ² AWG 17 control circuit Screw connector - flexible with cable end 1 0.5...1.5 mm ² AWG 16 control circuit 4 mm screw clamp terminal - flexible without cable end 1 1.5...10 mm ² AWG 8 power circuit Screw connector - flexible without cable end 1 0.5...2.5 mm ² AWG 14 control circuit 4 mm screw clamp terminal - flexible with cable end 2 1...6 mm ² AWG 10 power circuit 4 mm screw clamp terminal - flexible without cable end 2 1.5...6 mm ² AWG 10 power circuit Screw connector - flexible without cable end 2 0.5...1.5 mm ² AWG 16 control circuit |
| Marking | CE |
| Operating position | Vertical +/- 10 degree |
| Height | 12.4 in (314 mm) |
| Width | 1.8 in (45 mm) |
| Depth | 6.7 in (170 mm) |
| Net Weight | 1.08 lb(US) (0.49 kg) |
| Motor power range AC-3 | 4...6 kW 200...240 V 3 phase 7...11 kW 380...440 V 3 phase |
| Motor starter type | Soft starter |

Environment

| | |
|---------------------------------------|--|
| Electromagnetic compatibility | Conducted and radiated emissions level B CISPR 11 Conducted and radiated emissions level B IEC 60947-4-2 Damped oscillating waves level 3 IEC 61000-4-12 Electrostatic discharge level 3 IEC 61000-4-2 EMC immunity EN 50082-1 EMC immunity level B EN 50082-2 Harmonics level 3 IEC 1000-3-2 Harmonics level 3 IEC 1000-3-4 Immunity to electrical transients level 4 IEC 61000-4-4 Immunity to radiated radio-electrical interference level 3 IEC 61000-4-3 Voltage/Current impulse level 3 IEC 61000-4-5 Conducted and radiated emissions level 3 IEC 61000-4-6 Immunity to conducted interference caused by radio-electrical fields level 4 IEC 61000-4-11 |
| Standards | EN/IEC 60947-4-2 |
| Product Certifications | C-tick[RETURN]CSA[RETURN]UL[RETURN]CCC |
| IP Degree of Protection | IP20 |
| Pollution degree | 2 EN/IEC 60947-4-2 |
| Vibration resistance | 1 gn 13...150 Hz)EN/IEC 60068-2-6 1.5 mm peak to peak 3...13 Hz)EN/IEC 60068-2-6 |
| Shock resistance | 15 gn 11 ms EN/IEC 60068-2-27 |
| Relative humidity | 5...95 % without condensation or dripping water EN/IEC 60068-2-3 |
| Ambient air temperature for operation | 14...104 °F (-10...40 °C) without derating) 104...122 °F (40...50 °C) with current derating of 2 % per °C) |
| Ambient air temperature for storage | -13...158 °F (-25...70 °C) EN/IEC 60947-4-2 |
| Operating altitude | <= 3280.84 ft (1000 m) without derating > 3280.84 ft (1000 m) with current derating of 2.2 % per additional 100 m |

Ordering and shipping details

| | |
|-------------------|---------------|
| Category | US10I1122392 |
| Discount Schedule | 0I11 |
| GTIN | 3389110667110 |
| Returnability | Yes |
| Country of origin | DE |

Packing Units

| | |
|------------------------------|----------------------------|
| Unit Type of Package 1 | PCE |
| Number of Units in Package 1 | 1 |
| Package 1 Height | 1.969 in (5.000 cm) |
| Package 1 Width | 5.906 in (15.000 cm) |
| Package 1 Length | 6.772 in (17.200 cm) |
| Package 1 Weight | 19.541 oz (554.000 g) |
| Unit Type of Package 2 | S03 |
| Number of Units in Package 2 | 14 |
| Package 2 Height | 11.811 in (30.000 cm) |
| Package 2 Width | 11.811 in (30.000 cm) |
| Package 2 Length | 15.748 in (40.000 cm) |
| Package 2 Weight | 18.530 lb(US) (8.405 kg) |
| Unit Type of Package 3 | P06 |
| Number of Units in Package 3 | 112 |
| Package 3 Height | 29.528 in (75.000 cm) |
| Package 3 Width | 23.622 in (60.000 cm) |
| Package 3 Length | 31.496 in (80.000 cm) |
| Package 3 Weight | 169.835 lb(US) (77.036 kg) |

Offer Sustainability

| | |
|----------------------------|---|
| California proposition 65 | WARNING: This product can expose you to chemicals including: Lead and lead compounds, which is known to the State of California to cause cancer and birth defects or other reproductive harm. For more information go to www.P65Warnings.ca.gov |
| REACH Regulation | REACH Declaration |
| REACH free of SVHC | Yes |
| EU RoHS Directive | Pro-active compliance (Product out of EU RoHS legal scope) EU RoHS Declaration |
| Toxic heavy metal free | Yes |
| Mercury free | Yes |
| China RoHS Regulation | China RoHS Declaration |
| RoHS exemption information | Yes |
| WEEE | The product must be disposed on European Union markets following specific waste collection and never end up in rubbish bins. |

Contractual warranty

| | |
|----------|-----------|
| Warranty | 18 months |
|----------|-----------|

Dimensions

With TeSys U Combination (Non Reversing Power Base)

Mounting on symmetrical (35 mm) rail with power connector between ATS and TeSys U.

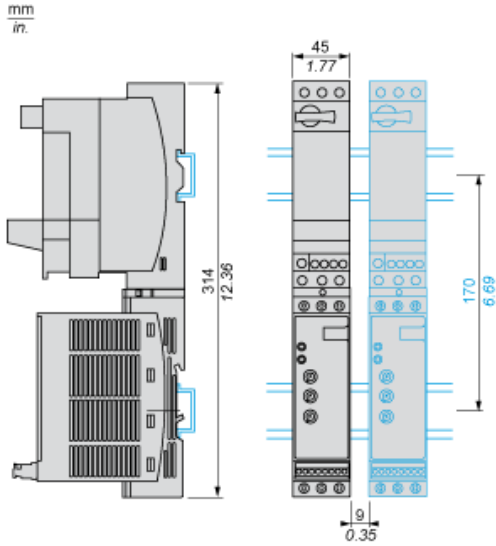

With TeSys U Combination (Non Reversing or Reversing Power Base)

Side by side mounting

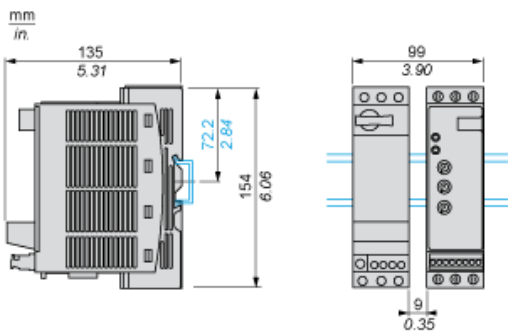

Power Wiring

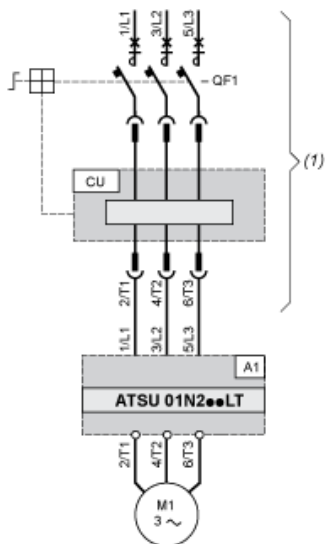

- (1) TeSys U
A1 : Soft start/soft stop unit
QF1 : TeSys U controller-starter
CU : TeSys U control unit

With Reversing Unit

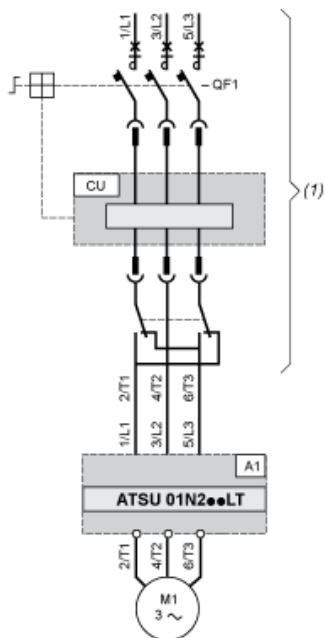

- (1) TeSys U with reversing unit
A1 : Soft start/soft stop unit
QF1 : TeSys U controller-starter
CU : TeSys U control unit

Control Wiring

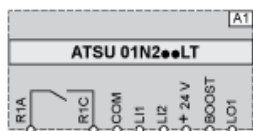

A1 : Soft start/soft stop unit

R1A, Relay output NO

R1C :

COM Commun

L11, Logic inputs (stop and run functions)

L12 :

BOOST Logic input (boost on start-up function)

LO1 : Logic output

Functional Diagram Automatic 2-wire Control

Without Deceleration

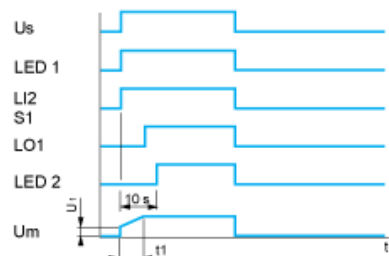

Us : Power supply voltage
LED Green LED
1 :
LI2 : Logic input
S1 : Pushbutton
LED Yellow LED
2 :
Um : Motor voltage
t1 : Acceleration time can be controlled by a potentiometer
U1 : Starting time can be controlled by a potentiometer

With and without Deceleration

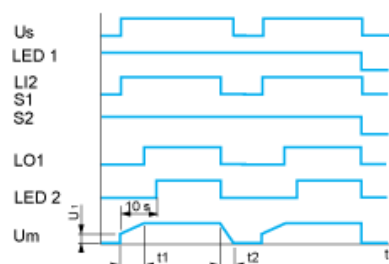

Us : Power supply voltage
LED Green LED
1 :
LI2 : Logic input
S1, Pushbuttons
S2 :
LO1 : Logic output
LED Yellow LED
2 :
Um : Motor voltage
t1 : Acceleration time can be controlled by a potentiometer
t2 : Deceleration time can be controlled by a potentiometer
U1 : Starting time can be controlled by a potentiometer

Functional Diagram Automatic 3-wire Control

Without Deceleration

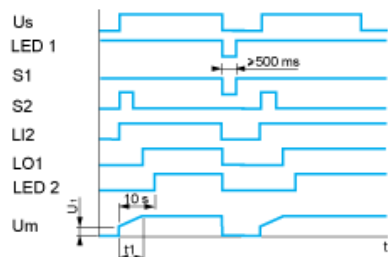

Us : Power supply voltage

LED Green LED

1 :

S1, Pushbuttons

S2 :

LI2 : Logic input

LO1 : Logic output

LED Yellow LED

2 :

Um : Motor voltage

t1 : Acceleration time can be controlled by a potentiometer

U1 : Starting time can be controlled by a potentiometer

With Deceleration



Us : Power supply voltage

LED Green LED

1 :

S1, Pushbuttons

S2 :

LI1, Logic inputs

LI2 :

LO1 : Logic output

LED Yellow LED

2 :

Um : Motor voltage

t1 : Acceleration time can be controlled by a potentiometer