



Main

Range of product	Telemecanique Safety switches XCS
Product or component type	Preventa RFID safety switch
Component name	XCSRC

Complementary

Design	Rectangular, standard
Size	Transponder 50 x 15 x 15 mm Reader 108.3 x 30 x 15 mm
Material	Valox
Electrical connection	1 male connector
Connector type	M12 male
Type of output stage	Solid-state, PNP
Safety outputs	2 NO
Number of poles	5
Local signalling	Green, orange and red 2 multi-colour LEDs
[Sao] assured operating sensing distance	0.39 in (10 mm) face to face
[Sar] assured release sensing distance	1.38 in (35 mm) face to face
Approach directions	3 directions-transponder with rotary sensing face
[Ue] rated operational voltage	24 V DC - 20...10 %)SELV or PELV EN/IEC 60204-1
[Ie] rated operational current	60 mA
[Ui] rated insulation voltage	30 V DC
[Uimp] rated impulse withstand voltage	0.8 kV IEC 60947-5-2
Protection type	Short-circuit protection
Maximum switching voltage	26.4 V DC
Switching capacity in mA	200 mA
Switching frequency	<= 0.5 Hz
risk time	120 ms
Response time	120 ms typical
Maximum delay first up	5 s
Tightening torque	< 1.5 N.m
Standards	EN/IEC 60947-5-3 EN/IEC 60947-5-2 ISO 14119
Product certifications	EAC E2 IC RCM CSA 22-2 FCC TÜV Ecolab

Marking	TÜV FCC EAC RCM CULus IC CE
Safety level	SIL 3 EN/IEC 61508 SILCL 3 EN/IEC 62061 PL = e EN/ISO 13849-1 Category 4 EN/ISO 13849-1
Safety reliability data	PFH_D = 5E-10/h EN/IEC 62061 PFH_D = 5E-10/h EN/ISO 13849-1
Mission time	20 year(s)
Ambient air temperature for operation	-25...70 °C
Ambient air temperature for storage	-40...185 °F (-40...85 °C)
Vibration resistance	10 gn (f= 10...150 Hz) conforming to EN/IEC 60068-2-6
Shock resistance	30 gn 11 ms EN/IEC 60068-2-27
Electrical shock protection class	Class III EN/IEC 61140
IP degree of protection	IP65 conforming to EN/IEC 60529 IP66 conforming to EN/IEC 60529 IP67 conforming to EN/IEC 60529 IP69K conforming to DIN 40050

Ordering and shipping details

Category	22455 - LIGHT CURTAINS - XUSL
Discount Schedule	DS2
GTIN	00785901027058
Nbr. of units in pkg.	1
Package weight(Lbs)	0.5 lb(US) (0.23 kg)
Returnability	Yes
Country of origin	FR

Packing Units

Unit Type of Package 1	PCE
Package 1 Height	1.65 in (4.2 cm)
Package 1 width	5.79 in (14.7 cm)
Package 1 Length	6.42 in (16.3 cm)
Unit Type of Package 2	BAG
Number of Units in Package 2	1
Package 2 Weight	3.63 oz (103 g)
Package 2 Height	0.59 in (1.5 cm)
Package 2 width	5.71 in (14.5 cm)
Package 2 Length	3.94 in (10 cm)
Unit Type of Package 3	S01
Number of Units in Package 3	12
Package 3 Weight	3.25 lb(US) (1.475 kg)
Package 3 Height	5.91 in (15 cm)
Package 3 width	5.91 in (15 cm)
Package 3 Length	15.75 in (40 cm)

Offer Sustainability

Sustainable offer status	Green Premium product
California proposition 65	WARNING: This product can expose you to chemicals including: Diisononyl phthalate (DINP), which is known to the State of California to cause cancer, and Di-isodecyl phthalate (DIDP), which is known to the State of California to cause birth defects or other reproductive harm. For more information go to www.P65Warnings.ca.gov
REACH Regulation	REACH Declaration
EU RoHS Directive	Pro-active compliance (Product out of EU RoHS legal scope) EU RoHS Declaration
Mercury free	Yes
RoHS exemption information	Yes
Environmental Disclosure	Product Environmental Profile

Connections

M12 Connector, 5-pin

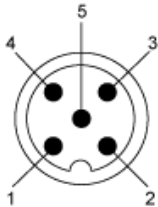

- (1) + 24 VDC
- (2) OSSD2
- (3) 0 VDC
- (4) OSSD1
- (5) NC (Not connected)

Connections

Wiring Diagram: Connection to a Safety Relay

Cat. 4 / PL=e (EN/ISO 13849-1) / SIL3 (IEC 61508) / SILCL3 IEC 62061), if combined with an appropriate Preventa XPS Safety unit PL=e / SIL3

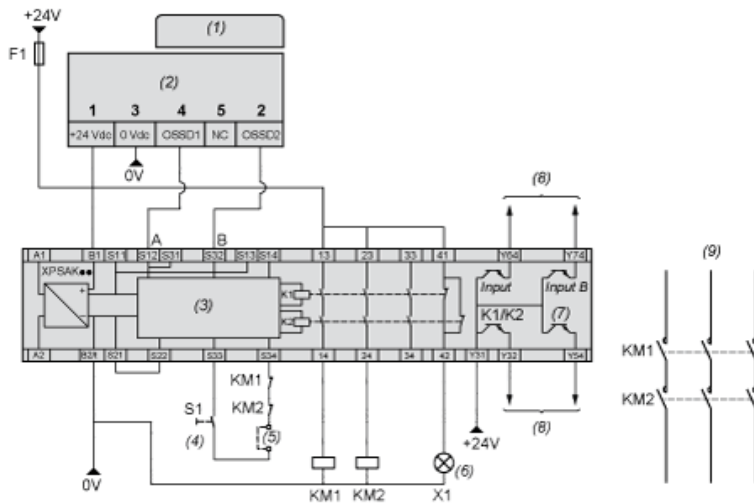

- (1) Transponder
- (2) Reader
- (3) Logic
- (4) Start
- (5) ESC: External start conditions
- (6) H1: indicator light deactivated
- (7) Fuse. Operating status of internal electronic fuse
- (8) To PLC
- (9) Power circuit

NOTE: KM1 and KM2 contactors must have force-guided contacts.

Connections

Wiring Diagram: Connection to a Safety Controller

Cat. 4 / PL=e (EN/ISO 13849-1) / SIL3 (IEC 61508) / SILCL3 IEC 62061), if combined with an appropriate Preventa XPS Safety controller PL=e / SIL3

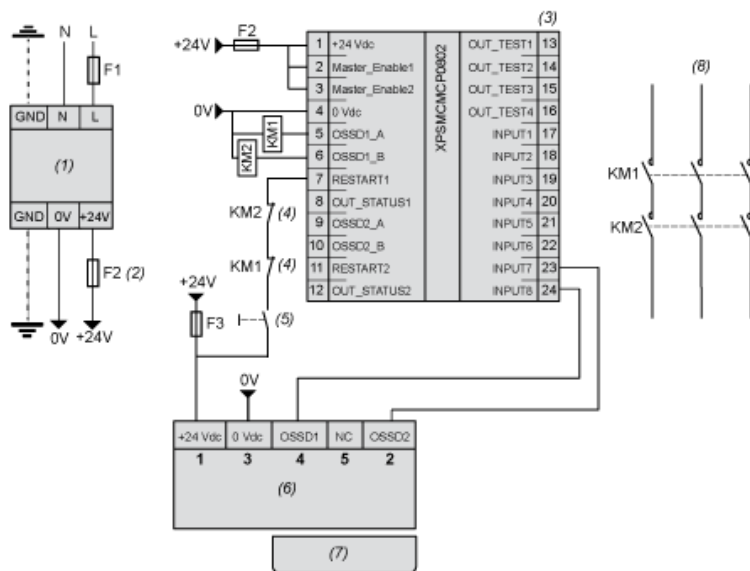

- (1) Power supply
- (2) 1 A max.
- (3) Safety controller
- (4) Feedback
- (5) Restart
- (6) Reader
- (7) Transponder
- (8) Power circuit

NOTE: KM1 and KM2 contactors must have force-guided contacts.

Mounting and Clearance

Face to Face Mounting (Preferred Configuration)

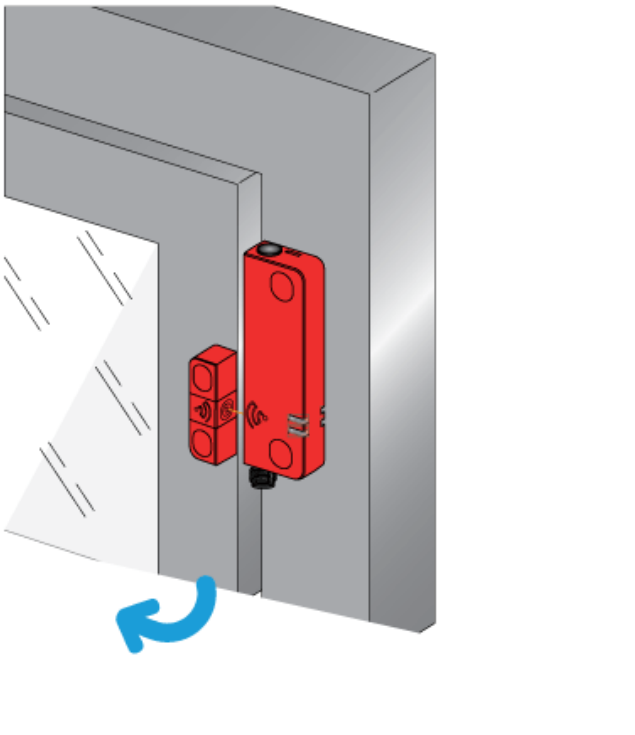
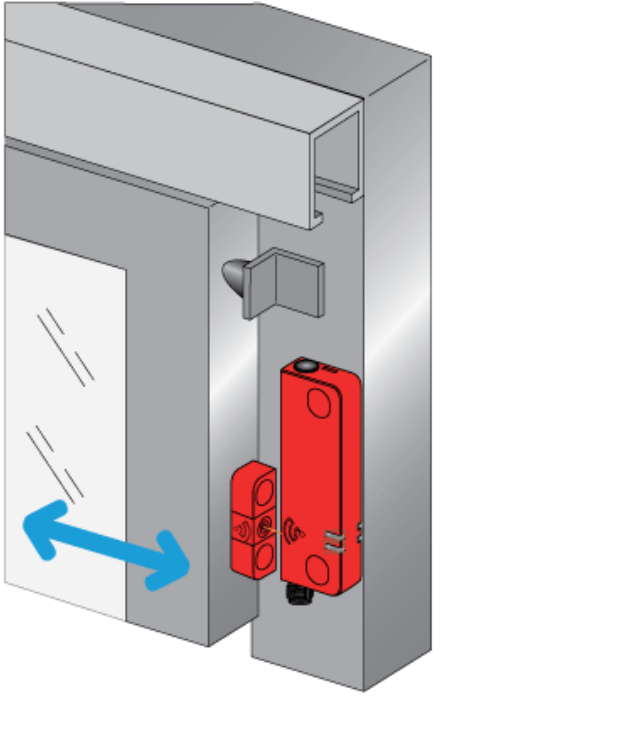
Example n°1	Example n°2
 <p data-bbox="236 1281 539 1482"> $e \text{ min.} = 2 \text{ mm}$ $e \text{ min.} = 0.08 \text{ in.}$ </p> <p data-bbox="145 1503 710 1554">e: Recommended minimum mounting distance between transponder and reader.</p>	 <p data-bbox="874 1281 1177 1482"> $e \text{ min.} = 2 \text{ mm}$ $e \text{ min.} = 0.08 \text{ in.}$ </p> <p data-bbox="815 1503 1380 1554">e: Recommended minimum mounting distance between transponder and reader.</p>

Face to Face Mounting (Preferred Configuration)

Example n°3

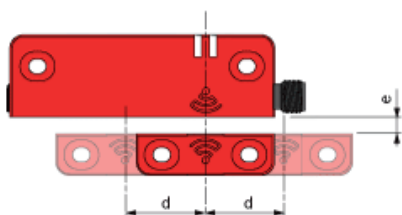
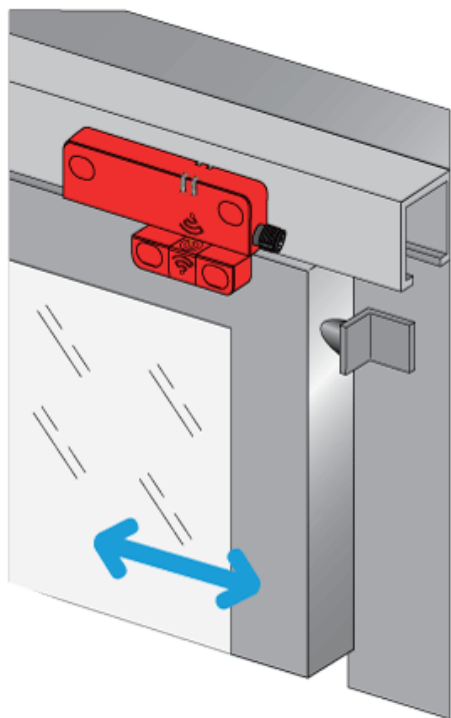

e > 2 mm. (e: recommended minimum mounting distance between transponder and reader)
min.

d : Detection limit

Mounting and Clearance

Side by Side Mounting

Correct Mounting Configuration

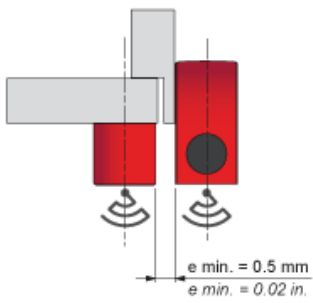
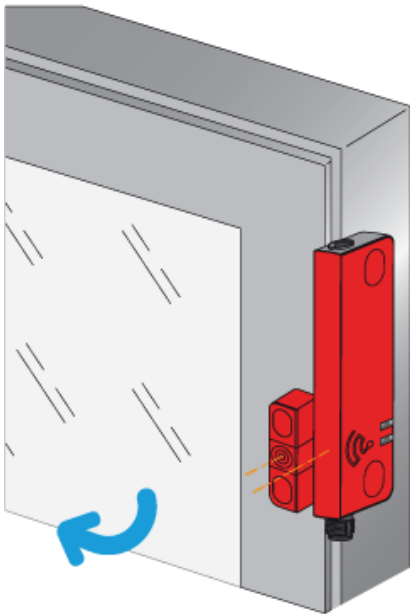

e: Recommended minimum mounting distance between transponder and reader.

Mounting and Clearance

Minimum Mounting Clearances between Safety Switches

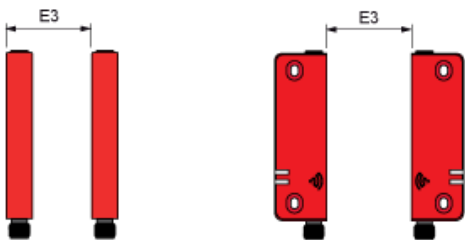
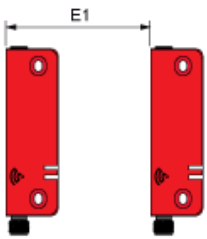

Dimensions in mm

E1 min.	E2 min.	E3 min.
45	150	65

Dimensions in in.

E1 min.	E2 min.	E3 min.
1.77	5.91	2.56

Detection Curves

Face to Face Mounting (Preferred Configuration)

Sao and Sar sensing distances along Y axis as function of Z (longitudinal misalignment for X=0)

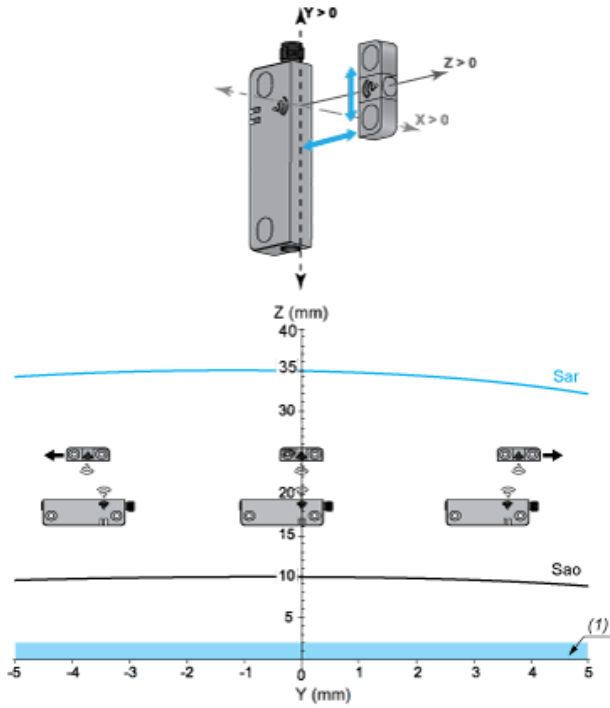

Sar: Assured release distance

Sao: Assured operating distance

(1) Recommended minimum mounting distance between transponder and reader.

Sao and Sar sensing distances along X axis as function of Z (transverse misalignment for Y=0)

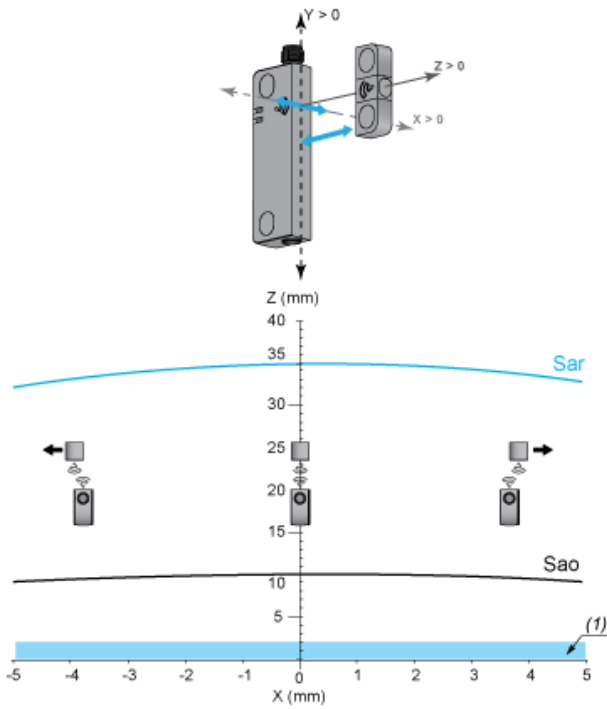

Sar: Assured release distance
 Sao: Assured operating distance
 (1) Recommended minimum mounting distance between transponder and reader.

Detection Curves

Side by Side Mounting

Sao and Sar sensing distances along Y axis as function of X (longitudinal misalignment for Z=0mm)

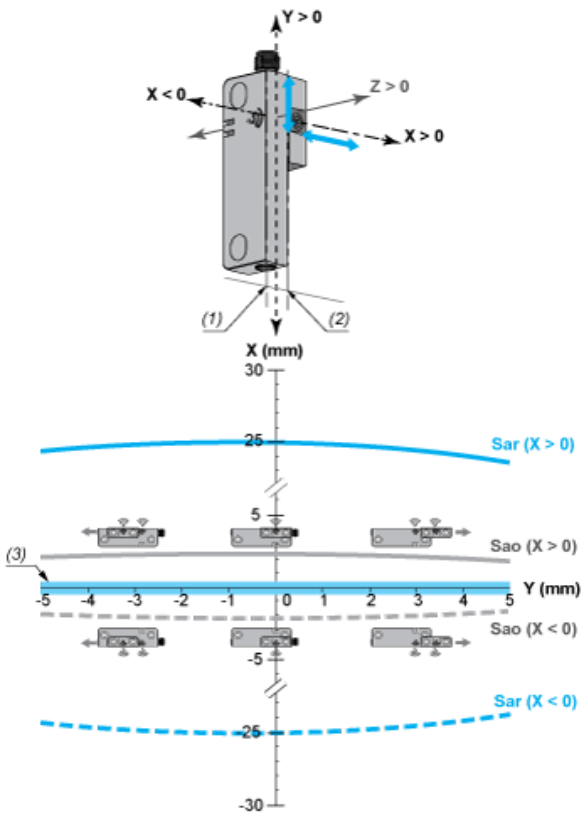

Sar: Assured release distance
 Sao: Assured operating distance
 (1) $X=0$ for $X < 0$
 (2) $X=0$ for $X > 0$
 (3) Recommended minimum mounting distance between transponder and reader.

Sao and Sar sensing distances along Z axis as function of X (transverse misalignment for Y=0mm)

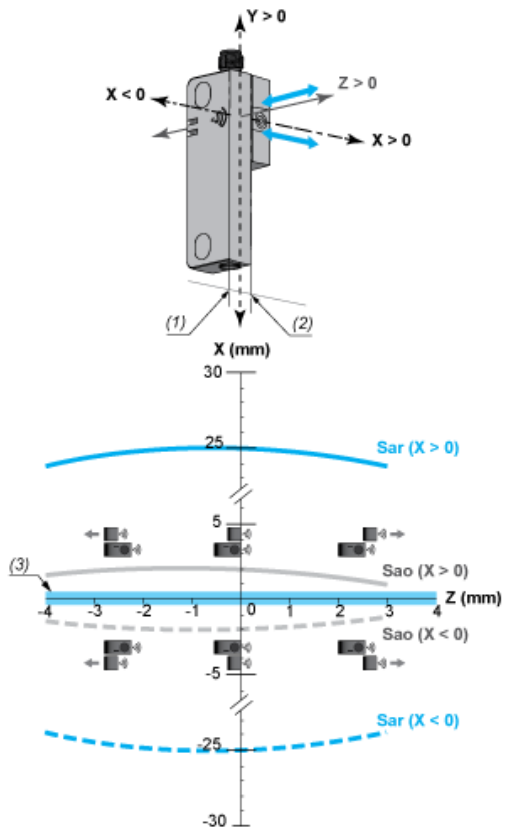

Sar: Assured release distance

Sao: Assured operating distance

(1) $X=0$ for $X < 0$

(2) $X=0$ for $X > 0$

(3) Recommended minimum mounting distance between transponder and reader.