



### Main

Range of product	Preventa XY2
Product or component type	Latching emergency stop rope pull switch
Device short name	XY2CH
Housing colour	Red RAL 3000
Overtoltage category	Class I EN/IEC 61140 Class I NF C 20-030

### Complementary

Local signalling	Without pilot light
Number of cables	1
Trigger cable maximum length	98.43 ft (30 m)
Body material	Zamak
Cover material	Stainless steel
Reset	By booted push-button
Contacts type and composition	1 NC + 1 NO
Contact operation	Slow-break
Trigger cable anchor point	RH or LH side
Connections - terminals	Screw clamp terminal, 1 x 0.5...2 x 1.5 mm <sup>2</sup>
Tightening torque	7.08...10.62 lbf.in (0.8...1.2 N.m)
Cable entry number	3 tapped entry 1/2" NPT conduit entry
Safety level	Can reach PL = e with the appropriate monitoring system and correctly wired EN/ISO 13849-1 Can reach category 4 with the appropriate monitoring system and correctly wired EN/ISO 13849-1 Can reach SIL 3 with the appropriate monitoring system and correctly wired EN/IEC 61508
Safety reliability data	B10d = 4000000 value given for a life time of 20 years limited by mechanical or contact wear IEC 60947-5-5
Marking	CE
Mechanical durability	800000 cycles
Distance between cable supports	16.40 ft (5 m)
[Ie] rated operational current	3 A 240 V, AC-15, A300 EN/IEC 60947-5-1 appendix A 0.27 A 250 V, DC-13, Q300 EN/IEC 60947-5-1 appendix A
[Ithe] conventional enclosed thermal current	10 A
[Ui] rated insulation voltage	500 V 3)EN/IEC 60947-1 300 VUL 508 300 VCSA C22.2 No 14
[Uimp] rated impulse withstand voltage	6 kV EN/IEC 60947-1
Positive opening	With EN/IEC 60947-5-1
Maximum resistance across terminals	25 MOhm EN/IEC 60255-7 category 3 25 MOhm NF C 93-050 method A
Short-circuit protection	10 A cartridge fuse gG EN/IEC 60269
Terminals description ISO n°1	(13-14)NO (21-22)NC

Net Weight	1.91 lb(US) (0.865 kg)
Compatibility code	XY2CH

## Environment

Standards	UL 508 EN/IEC 60947-5-5 CSA C22.2 No 14 Work equipment directive 2009/104/EC EN/ISO 13850 EN/IEC 60947-5-1 EN/IEC 60204-1 Machinery directive 2006/42/EC
Product certifications	UL category NISD emergency stop devices CSA CCC
Protective treatment	TC
Ambient air temperature for operation	-13...158 °F (-25...70 °C)
Ambient air temperature for storage	-40...158 °F (-40...70 °C)
Vibration resistance	10 gn 10...150 Hz)EN/IEC 60068-2-6
Shock resistance	50 gn 11 ms EN/IEC 60068-2-27
IP degree of protection	IP65 IEC 60529



## Ordering and shipping details

Category	22441 - LIMIT SWITCHES,CABLE PULL
Discount Schedule	T
GTIN	00785901722137
Nbr. of units in pkg.	1
Package weight(Lbs)	2.31 lb(US) (1.05 kg)
Returnability	Yes
Country of origin	MA

## Packing Units

Unit Type of Package 1	PCE
Package 1 Height	3.62 in (9.2 cm)
Package 1 width	7.72 in (19.6 cm)
Package 1 Length	3.23 in (8.2 cm)
Unit Type of Package 2	S03
Number of Units in Package 2	10
Package 2 Weight	23.54 lb(US) (10.678 kg)
Package 2 Height	11.81 in (30 cm)
Package 2 width	11.81 in (30 cm)
Package 2 Length	15.75 in (40 cm)

## Offer Sustainability

Sustainable offer status	Green Premium product
EU RoHS Directive	Pro-active compliance (Product out of EU RoHS legal scope)  <a href="#">EU RoHS Declaration</a>
Mercury free	Yes
RoHS exemption information	 Yes
Environmental Disclosure	 <a href="#">Product Environmental Profile</a>

## Contractual warranty

Warranty	18 months
----------	-----------

Dimensions

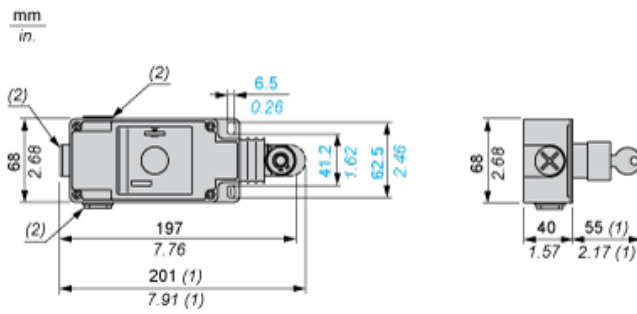

- (1) Maximum extension.
- (2) Tapped entry for 1/2" NPT

Electrical Curves

AC Supply 50/60 Hz Inductive Circuit

2-pole Contact Block

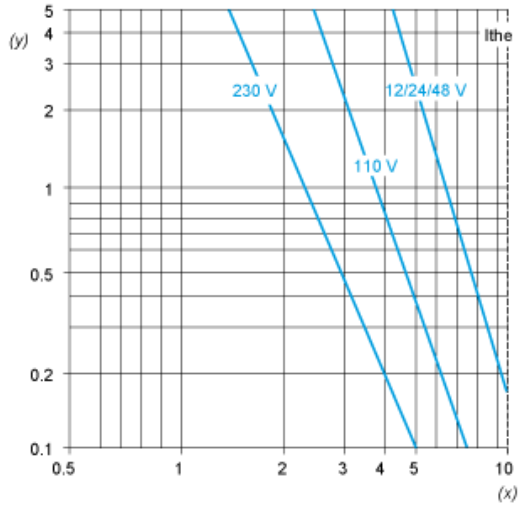

Y Millions of operating cycles  
X Current in A

DC Supply Power Broken in for 1 Million Operating Cycles Inductive Circuit

Voltage	V	24	48	120
$P_{max}$	W	13	9	7