



► Model 151XST

# Hazardous Location Warning Light



Model 151XST hazardous location strobe light provides 80 high-intensity flashes per minute. This hazardous location warning light has an aluminum base, coated for corrosion-resistance, that can be ordered for mounting on a 3/4-inch NPT pipe or a surface. The Dome Guard (included) fits over the glass dome to protect it against accidental collision with moving equipment, such as forklifts.

Federal Signal's rugged 151XST strobe warning light is specifically designed for hazardous locations or corrosive environments where a very bright visual signal is required. This warning light can be used for plant evacuation or other communication needs.

## FEATURES

- Available in 12-24VDC, 120VAC and 240VAC
- Five dome colors: Amber, Blue, Clear, Green and Red
- 10,000-hour high-intensity strobe
- Available in 3/4-inch NPT pipe mount or surface mount
- Dome guard included
- Indoor/outdoor use
- Type 4X, IP66 enclosure
- Marine rated
- UL and cUL Listed for Class I, Division 1 and 2, Groups C and D; Class I, Division 2, Groups A and B; Class II, Division 1, Groups E, F, and G and Class III

| MODEL                    | VOLTAGE        | OPERATING CURRENT | FLASH RATE/ MINUTE | CANDELA           |                  |
|--------------------------|----------------|-------------------|--------------------|-------------------|------------------|
|                          |                |                   |                    | PEAK <sup>1</sup> | ECP <sup>2</sup> |
| <b>151XST-*012-024**</b> | 12-24VDC       | 1.3-0.60 amps     | 80                 | 520,000           | 165              |
| <b>151XST-*120**</b>     | 120VAC 50/60Hz | 0.35 amps         | 80                 | 520,000           | 165              |
| <b>151XST-*240**</b>     | 240VAC 50/60Hz | 0.18 amps         | 80                 | 520,000           | 165              |

\* Include (S) for Surface Mount Option (Example part number: 151XST-S120R for surface mount option, 151XST-120R for pipe mount)

\*\* Indicates color: (A) Amber, (B) Blue, (C) Clear, (G) Green or (R) Red

<sup>1</sup> Peak candela is the maximum light intensity generated by a flashing light during its light pulse

<sup>2</sup> ECP (Effective Candela) is the intensity that would appear to an observer if the light were burning steadily

### HAZARDOUS LOCATION RATING: 151XST

T-CODE AT MAXIMUM AMBIENT TEMPERATURE, °C

|  |             |
|--|-------------|
| <b>Hazardous Location</b>              | <b>40°C</b> |
| Class I, Division 2, Groups A, B, C, D | T2A         |
| Class II, Division 1, Groups E, F, G   | T5          |
| Class III                              | T5          |

# Hazardous Location Strobe Light (151XST)

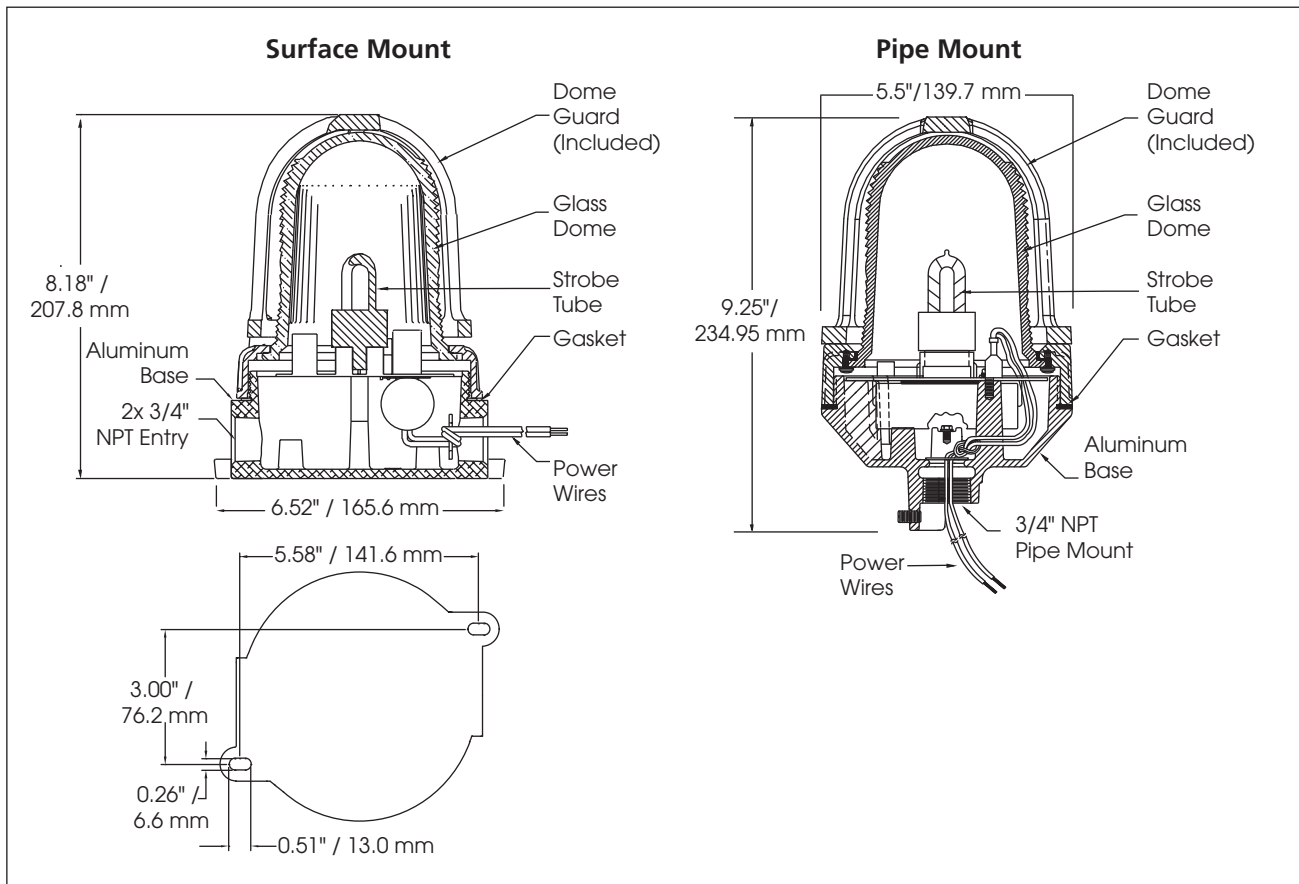

## SPECIFICATIONS

|                        |                |               |
|------------------------|----------------|---------------|
| Lamp Life:             | 10,000 Hours   |               |
| Light Source:          | Strobe tube    |               |
| Operating Temperature: | -67°F to 150°F | -55°C to 66°C |
| Net Weight:            | 3.8 lbs        | 1.7 kg        |
| Shipping Weight:       | 4.5 lbs        | 2.0 kg        |
| Pipe Mount             |                |               |
| Height:                | 9.25"          | 234.95 mm     |
| Diameter:              | 5.5"           | 139.7 mm      |
| Surface Mount          |                |               |
| Height:                | 8.18"          | 207.8mm       |
| Diameter               | 6.52"          | 165.6mm       |

## REPLACEMENT PARTS

| Description                              | Part Number  |
|--|--------------|
| <b>Series C Dome and Ring Assembly</b>   |              |
| Dome & Ring Assembly, Amber <sup>1</sup> | K8449078C-01 |
| Dome & Ring Assembly, Blue <sup>1</sup>  | K8449078C-06 |
| Dome & Ring Assembly, Clear <sup>1</sup> | K8449078C-04 |
| Dome & Ring Assembly, Green <sup>1</sup> | K8449078C-07 |
| Dome & Ring Assembly, Red <sup>1</sup>   | K8449078C    |
| PC Assembly, 12-24VDC                    | K2001173A    |
| PC Assembly, 120VAC                      | K2001071B    |
| PC Assembly, 240VAC                      | K2001071B-01 |
| Strobe Tube                              | K149122B     |
| Dome Guard                               | K8449090B    |

<sup>1</sup> Includes dome gasket

## HOW TO ORDER

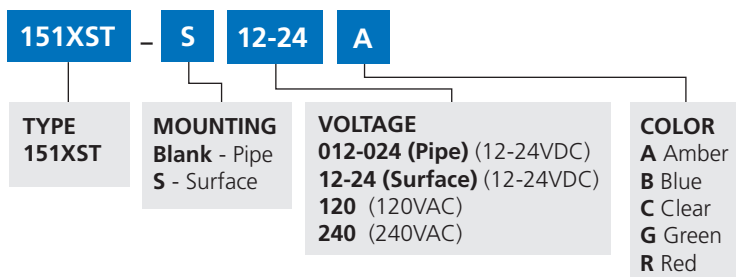

## OPTIONAL ACCESSORIES

| Description                         | Part Number |
|-------------------------------------|-------------|
| Hazardous Location Mounting Bracket | LHWB        |

Mounting Brackets shown on pages 130-131